



1200

OPERATING MANUAL



© Copyright CFS 2010

CFS M1200 Operating Manual
TABLE OF CONTENTS

<u><i>TOPIC</i></u>	<u><i>PAGE #</i></u>
• Introduction	3
• Technical Specifications	4
• Optional Equipment	5
 <u>SECTION 1: Operational Safety</u>	
• Electrical Safety	6
• Mechanical Safety	7
 <u>SECTION 2: Operation Procedures</u>	
• Electrical Supply	8
• Water Supply & Chemicals	10
• Chemical Metering Tips	11
• Water Supply	12
• Solution Hose & Pump Priming	13
• Vacuum Hoses	14
• Pump-Out System	16
• Pressure Adjustments	17
• Shutdown Procedures	18
• Troubleshooting	19-21
• Solution Flow Path	22
• Wiring Diagrams	23
 <u>SECTION 3: Maintenance/ Technical</u>	
• Maintenance	26
• Drawings & Parts Lists	
○ Pump	36
○ Auto-Fill	38
○ Pressure Regulator	39
○ Solution Tank	40
○ Waste Tank	42
○ Base & Vacuum System	44
○ Base, Pumps, Components	45
• Warranty	46

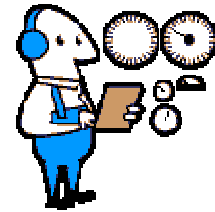

Introduction

Congratulations on your purchase of the CFS M1200. The CFS M1200 is designed to give truckmount-level performance in a portable machine that combines versatility with ease of transport. Years of experience, engineering, and planning have gone into the design and manufacturing of the CFS M1200. We take a great deal of pride in the CFS M1200; our goal is no less than your complete satisfaction.

This manual will provide users with the knowledge required to operate the CFS M1200 safely, to understand how to properly operate and maintain the machine, and to ensure that the equipment operates at its maximum performance level. **All users must read and understand this manual completely before operating the machine.**

Always maintain this manual in legible condition adjacent to the CFS M1200, or place in a secure location for future reference.

Any questions pertaining to the operating or servicing of this unit should be directed to HMS Manufacturing.

This manual is written specifically for the CFS M1200 portable extractor units manufactured by:

HMS Manufacturing LLC
3025 Concordia St.
Cincinnati, OH 45206-1109
513-751-4100
513-559-4161 FAX

Information in this manual is subject to change without notice and does not represent a commitment on the part of HMS Manufacturing or its parent or affiliated companies.

Technical Specifications

CFS M1200 High Pressure Extractor

Height: 38"

Length: 28"

Width: 19-1/2"

Weight: 141 lbs.

Solution Tank Capacity: 12 gallon

Recovery Tank Capacity: 12 gallon

Solution Pump: Pump-Tec #356 pump with 1-1/2 HP Motor
0-1200 psi – 2.2 gpm

Vacuum Motors: Two AMETEK Lamb 5.7" diameter – tangential discharge
One two stage & One three stage – Mounted in series

Pump-out Pump: Little Giant 120VAC 8-20 gpm
Maximum psi 11.4 – Maximum pumping height 26 ft.

Power Draw: Cord #1 – 18.60Amp wide open / 11.80amp full load
Cord #2 – 19.30Amp max total (14.30 Pump / 5.00 Waste Pump)

Standard Equipment

CFS M1200 High Pressure Extractor

Vacuum Hose: 25' X 1-1/2" with 1-1/2" cuff & 2" cuff
4' x 1-1/2" with 2" cuffs
Hydro-Filter Inline Filter - AC11
Foam Downer – AH17

HP Solution Hose: 25' x 1/4" ID with 1/4" male / female quick connects

Auto Fill System with chemical draw:

Metering Tip Kit: 14 different tips for changing chemical dilution rate

Water Supply Hose: 50' x 3/8" with 1/4" female quick connect &
female garden hose fitting

Auto Pump-out System:

Pump-out Hose: 50' x 3/4" with male & female garden hose fittings

Power Cords: 2 – 50' x 12gauge GFCI protected w/ male & female ends
Electrical: Breaker Buddy Circuit Detector
20amp Pump Circuit Breaker

Additional / Optional Equipment

Carpet Wand:

SX-12 Hard Surface Tool:

SX-7 Tile & Grout Tool:

Gekko Tile & Grout Wand:

Gekko Hand Tool:

Gekko SX-7 Tool:

1-1/2" Vacuum Hose - Blue: (25' - 1-1/2" cuffs)

2" cuff for 1-1/2" Vac Hose:

1-1/2" cuff for 1-1/2" Vac Hose:

2" Hose Connector PVC:

1-1/2" Hose Connector PVC:

HP Solution Hose 1/4" X 25' w/M-F Quick Connects

1/4" Male Quick Connect:

1/4" Female Quick Connect:

Pump-out Hose:

Replacement Bags for Hydro-Filter:

Metering Tip Kit:

AW29

AW104

AW101

AR54

AR52

AW102

AH38B

AH46

AH42

AH76

AH74

AH79AD

AH102B

AH101B

AH65

AC11A

PDE001



AW29



AW104



AW101



AR54



AR52

Safety

CAUTION! This machine is an electrical appliance. Care must be taken to reduce the risk of electrical shock.

- **READ AND UNDERSTAND ALL INSTRUCTIONS BEFORE OPERATING THE CFS M1200.**
- To reduce the risk of property damage or injury, repairs to electrical systems should only be performed by experienced technicians. Contact HMS Manufacturing.
- Unplug machine power cord from outlet before performing any repairs on the extractor.
- Plug unit into grounded outlets only. Do not remove ground prong from plug. **Use CFS M1200 with Ground Fault Circuit Interrupting (GFCI) cords only to reduce the risk of electrical shock.**
- Do not use the CFS M1200 outdoors, in standing water or on wet surfaces.
- Do not store the CFS M1200 in wet conditions.
- If extractor is leaking, unplug machine power cords from outlets before approaching or touching machine.
- Do not unplug power cord by pulling on the cord. Grasp the plug when unplugging the cord.
- Do not pull the extractor by the cord.
- If cord or plug is damaged, do not use cord. Replace with new cord or repair as needed before use.
- Any power cords used must be able to handle an electrical load of 20amps each.
- Overloaded circuit may not always trip circuit breaker. Reduced voltage to machine on overloaded circuit will prevent components from operating properly.
- The two power cords must be plugged into separate circuits during operation. Power Cord #1 must be on a 20amp circuit to use both vacuums. Power Cord #2 can be on a 15amp if the Auto Pump-out is not used or a 20amp circuit if it is used. The Breaker Buddy will ensure that the two cords are operating on different circuits (see page 8 for details.)

WARNING! This machine must be protected from conditions which may damage the pump, tank, hoses and other components.

- **Freezing of water in this machine will cause serious damage.** The CFS M1200, solution hoses, and tools must be protected from freezing temperature. Store, transport, and use this equipment only in temperatures well above freezing. (32°F or 0°C). If you suspect the CFS M1200 has been frozen, do not plug in or turn on machine until you are sure it has thawed completely.
- If the equipment cannot be stored or transported in a warm environment, it can be guarded from freezing by running an anti-freeze solution through the incoming water lines, chemical feed system, solution pump, solution lines, tools and pump-out pump. The machine is filled at the factory with anti-freeze to eliminate damage during shipment in cold weather.
 - The anti-freeze solution must be completely flushed from the machine before it is returned to service.
- The CFS M1200 must not be used to pick up flammable or combustible materials or used in areas where these materials may be present.
- Solvent-based or water-based solutions containing solvents may damage the pump, hoses, and other components. Do not assume chemical compatibility. Contact HMS Manufacturing if you have questions regarding the compatibility of your chemicals with the machine.
- Do not clean with solutions that are at temperatures above 140°F.
- Rinse the solution tank, chemical system, and pump with fresh water after each day's use.
- Do not allow pump to run dry. Always maintain adequate solution level to supply solution pump.
- HP hoses may rupture if worn or damaged. Do not use HP solution hoses if hose covering is cut, bulging, or otherwise damaged. Examine HP solution hoses daily and replace or repair hoses as needed.
- Use Hydro-Filter and clean the recovery tank daily to keep pump-out pump from becoming clogged. Store the CFS M1200 with the recovery tank lid open.
- Keep Vacuum Inlet Filter clean and check float ball for proper operation. Do not operate the CFS M1200 without the Vacuum Inlet Filter in place. **Use defoamer to eliminate foam build-up during cleaning and prevent foam/moisture from entering vacuums.**

*****Use common sense to protect yourself and others while using this equipment.*****

- Keep pets and children away from the machine when in use.
- Keep all body parts, hair, and loose clothing away from openings and moving parts. Always wear appropriate clothing and safety equipment when operating unit.
- Use extra care when cleaning on stairs. Wet carpet on stairs can be slippery.
- Do not move the CFS M1200 up or down stairs when tanks are full of water. Drain solution and recovery tanks before moving unit up or down stairs. Lift using only the appropriate handles.
- Water may be spilled, drip, or be exhausted from vacuums during operation. Place unit in area where water will not cause damage or use drop cloth to protect surfaces.

Operation Procedures

Knowledge of the proper operation of the CFS M1200 is required to ensure user safety and efficient performance of the extractor.

SET UP AND OPERATION

1. Electrical Cords:

Two 50' GFCI protected power cords are supplied with the CFS M1200. Cord #1 powers both vacuum motors; Cord #2 powers the high pressure solution pump and the waste pump. The amperage required by each cord requires that the two cords be plugged into separate circuits:

- Cord #1 (left side) will require a 20amp circuit to run both vacuums.
- Cord #2 (right side) can be plugged into a 15 amp circuit if Auto Pump-out is not used or a 20 amp circuit if the Auto Pump-out is used.

20amp circuits are usually found in kitchens and bathrooms.

Make sure no other items are plugged into these circuits. An overloaded circuit may not always trip the breaker, but may not provide sufficient power to operate the machine.

Plug the two power cords into two outlets from different circuits (Reset GFCI). If the Breaker Buddy green indicator light fails to light, you may be on the same circuit and may need to select a different plug for one of the cords.

- If the Breaker Buddy green indicator light comes on, you are plugged into two different circuits. Proceed with your set-up procedure.
- If a circuit breaker trips or the pump circuit breaker trips during operation, reset the breakers and move the cord to another outlet as needed.

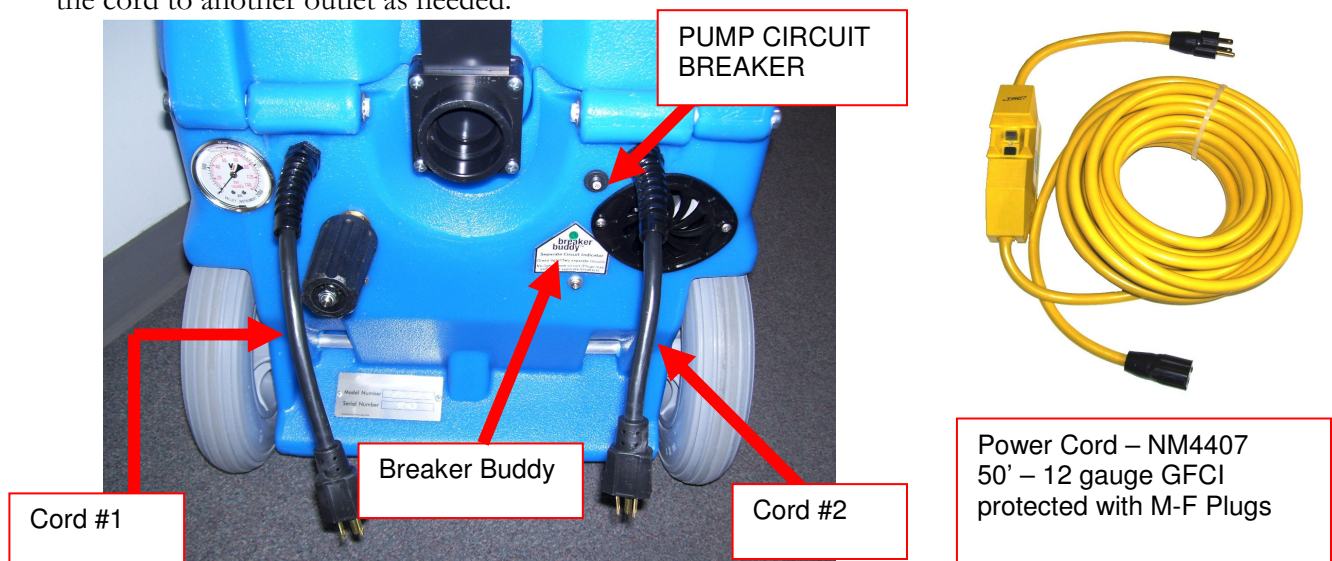

To reduce the risk of electrical shock, check the GFCI power cords for wear or damage and repair or replace as needed before each use:

Test GFCI and replace cord if GFCI is not operating properly.



RESET BUTTON

Green Indicator Light

TEST BUTTON

With the GFCI cords connected to the two different 120vac outlets, push the RESET Buttons. Then, push the TEST buttons to test both GFCI's.

- If RESET button pops out and green light turns off, push RESET button back in and proceed with M1200 set-up and operation.
- If RESET button does not pop out and green light stays on when the TEST button is pushed, replace cord or contact your nearest service center for advice or assistance.



RESET Button in ON position
Green Indicator Light ON

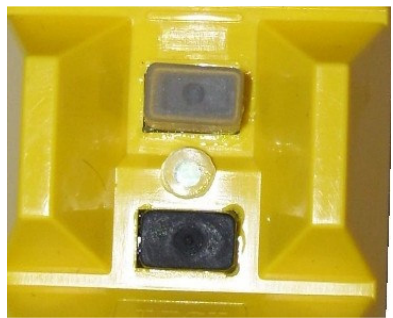

RESET Button in OFF position
Green Indicator Light OFF



To operate your CFS M1200 Push the GFCI RESET Button in to the ON position on both cords. The green indicator light must be ON for power to be supplied to the machine.

2A. Water Supply & Chemical Mixing– Manual Fill:

- Pour up to 12 gallons of hot water into the solution tank at the front of the machine. The water level must be high enough to lift and engage float switch for operation of solution pump. **The water temperature cannot exceed 140°F.**
- Measure and add the appropriate amount of the desired liquid chemical to the water in the solution tank. The amount of chemical will vary depending on the type of chemical used, the amount of water in the tank, and the material being cleaned; consult the chemical packaging for specific mixture ratios.
- Powdered chemicals should be dissolved in water before adding to the water in the solution tank.

DO NOT RUN OUT OF WATER WHILE USING THE MACHINE! Ensure that the tank contains enough water to complete each job. If the water level is low: the Solution Pump Float Switch should shut the pump off. If not, stop cleaning, turn off the pump, and refill the tank. Running the pump dry will damage the pump and void the warranty.



Pour the appropriate amount of hot water into the solution tank



Add appropriate amount of chemical to the hot water in the solution tank

2B. Water Supply & Chemical Dilution – Auto-Fill:

- The chemical dilution rate is controlled by the metering tip, and the dilution rate can only be changed by changing the metering tip (See “How to Change the Metering Tip” on Page 11 for instructions.)

Chemical Feed Setup:

- Remove the chemical feed hose from the solution tank. Make sure float is attached to valve and hanging freely.
- Place the end of the hose into a container of liquid chemical.
- If the tip is removed, and the proportioning system operated with no tip, the dilution rate will be 8:1 (the equivalent to adding 16-1/4oz of chemical to each gallon of water.)
- The standard tip included with the CFS M1200 is the turquoise tip with a dilution rate of 256:1. This means that for each gallon of water flowing into the machine, 1/2 ounce of chemical will be added.
- **If a fresh water rinse with no chemical is desired, simply leave the chemical feed hose inside the solution tank.**

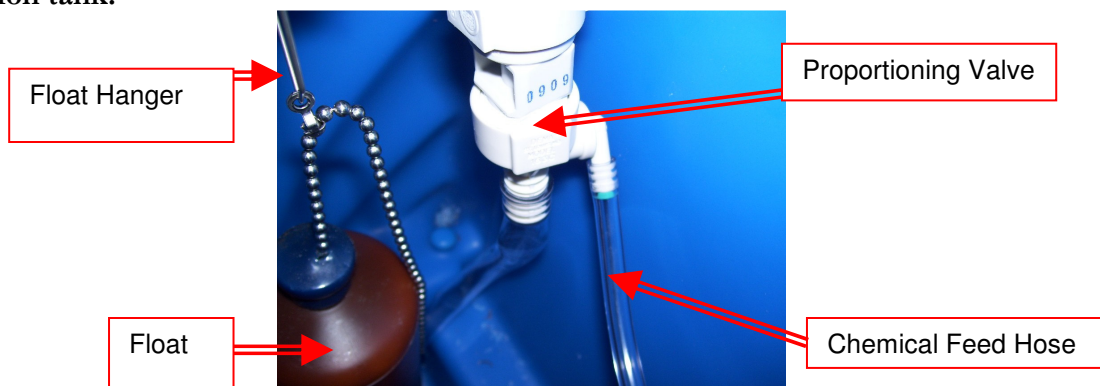

How to Change the Metering Tip:

- Remove the chemical feed hose from the barb on the side of the proportioning valve.
- Unscrew and remove the old tip.
- Screw in the proper tip for your chemical tip and place the hose back on the barb

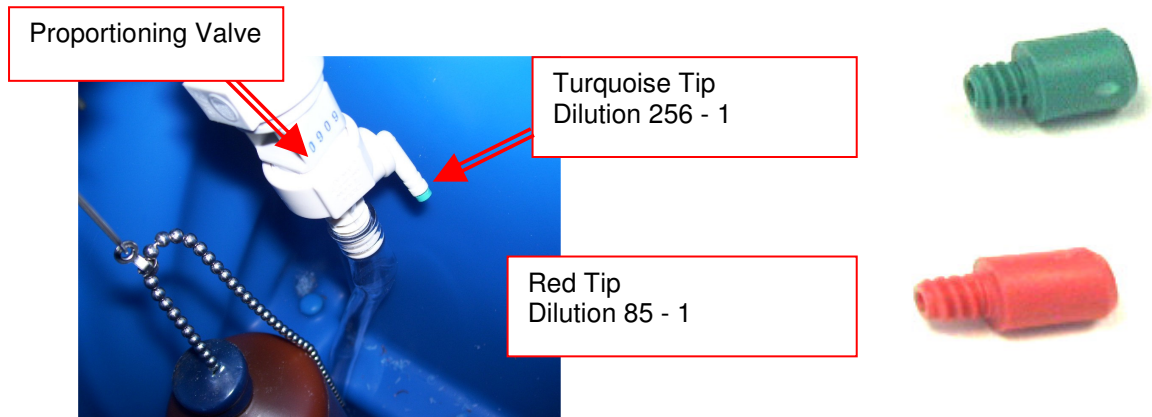

Metering Tip Kit – PDE001

Metering Tip Kit (Item# PDE001) contains 14 different colored metering tips, allowing dilution rates from 11:1 up to 427:1. Refer to the chart below to select the tip that meets the dilution rate for your chemical application.

- For example: if you require 1-1/2 ounces of chemical per gallon of water, change to the red metering tip with the dilution rate of 85:1.
- The dilution rates are based on chemicals with water-like viscosity. Thicker (more viscous) chemicals will dilute at a different rate.
- For powdered chemicals, a liquid concentrate must be made. Mix the concentrate according to the manufacturer’s directions, and then select the appropriate metering tip.
- Contact your HMS if you have questions about your chemical.

Metering Tip Application Chart:



TIP COLOR	CHEMICAL DILUTION RATES	
	OZ / GAL	(RATIO)
TAN	0.30	(427:1)
ORANGE	0.40	(320:1)
TURQUOISE	0.50	(256:1)
PINK	0.75	(170:1)
LIGHT BLUE	1.00	(128:1)
BROWN	1.12	(114:1)
RED	1.50	(85:1)
WHITE	1.75	(73:1)
GREEN	2.00	(64:1)
BLUE	2.50	(51:1)
YELLOW	3.75	(34:1)
BLACK	5.00	(26:1)
PURPLE	8.50	(15:1)
GRAY	11.50	(11:1)
NO TIP	16.25	(8:1)

Water Supply:

- Once the correct metering tip is in place:
 - Connect the Auto-Fill Water Supply Hose to the water inlet (the male quick-connect on the front of the machine.)
 - Connect the other end of the hose to a water faucet, and then turn on the water.
- Hot water can be used as long as the temperature does not exceed 140°F.
- Faucet adapter kits (item #AX21 & AX22) are available that allow connection to different types of faucets if needed.

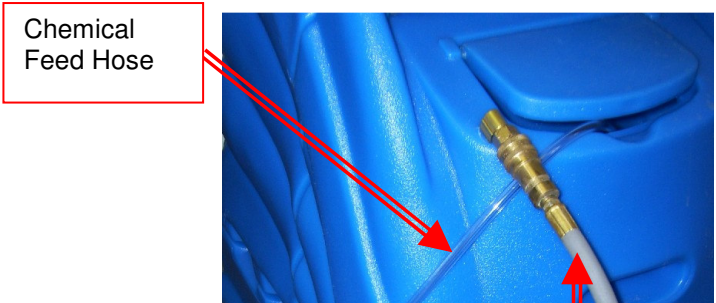

Connect the Auto-Fill Water Supply Hose to a faucet and turn on the water



Connect the Auto-Fill Water Supply Hose to Solution Inlet (Male quick connect on the front of the machine.)
3/8" id X 25' with F Quick Connect & F Garden Hose Fitting

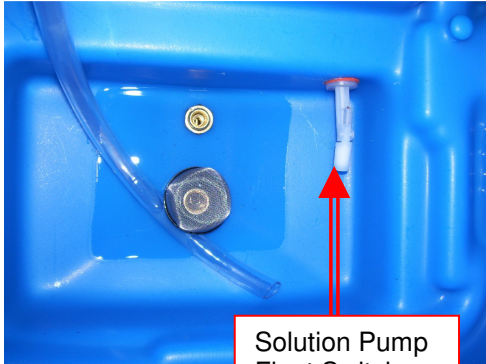

Solution Pump Float Switch

To adjust the water level in the solution tank:

- Turn off the water supply.
- Adjust the length of the chain connecting the float bottle to the float valve.
- Snap the beaded chain off the connector on the valve.
 - Move the bottle down to decrease the water level.
 - Move the bottle up to increase the water level.
- Snap the chain back into the connector.
- Turn the water supply back on.

The water level must be high enough to engage the Solution Pump Float Switch for solution pump operation.

If the chemical is not drawing, or if the tank is not filling or is overflowing, refer to the trouble shooting guide, or contact your distributor for assistance.

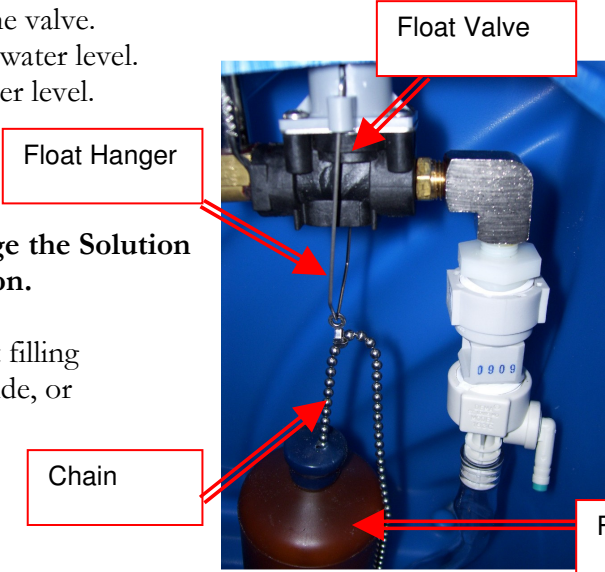

3. Connection of Solution Hose:

Connect the high pressure solution hose to the solution outlet (female quick connect on the front of the machine). Connect the other end of the hose to the male quick connect on the cleaning tool. When you are ready to start cleaning, turn the solution pump switch to the ON position



HP Solution Hose Assembly – AH79AD
1/4" ID X 25' with 1/4" M-F Quick Connects



Connect the male end of the HP Solution Hose Assembly to the female solution outlet fitting on the machine. Connect the female end to the cleaning tool.

4. Priming the High-Pressure Pump:

Once water is in the solution tank and the solution hose is connected, the high pressure pump must be primed:

- There is a prime valve located on the lower front portion of the machine.
- Turn on both vacuums and the solution pump. Press the priming lever for a few seconds while you block off the vacuum inlet with your hand. The vacuum will pull solution through the pump and prime valve into the vacuum tank.
- Let off the prime valve and your pump is primed. As long as there is solution in the tank the pump should remain primed.
- After priming, turn off the solution pump. If you have not yet connected your solution hose, or connected the hose to the tool the pressure may need to be released from the lines to allow the hose or tool to be connected.

If the pump still does not prime, or if flow is low or unsteady, check the hose from the solution tank to the pump (as well as the filter) for clogging, kinks, or restrictions. Clean or replace hose and/or filter and repeat the priming procedure.

If you are having trouble with the pump, refer to the trouble shooting guide or contact HMS for advice or assistance.



PRIME VALVE



5. Connection of Vacuum Hoses:

There are three components used to connect the cleaning tool to the vacuums and recovery tank:

1. A short 4' vacuum hose: Connected to the vacuum barb on the front of the machine and to the outlet side of the Hydro Filter.
2. A Hydro Filter
3. A 25' Vacuum Hose: The 2" cuff on the 25' vacuum hose is connected to the inlet side of the hydro filter. The other end with the 1-1/2" cuff is connected to the cleaning tool.

When ready to begin cleaning, turn both vacuum switches to the ON position. While the CFS M1200 can be operated with only one vacuum for cleaning delicate fabrics, in most situations you will turn both vacuum switches ON.

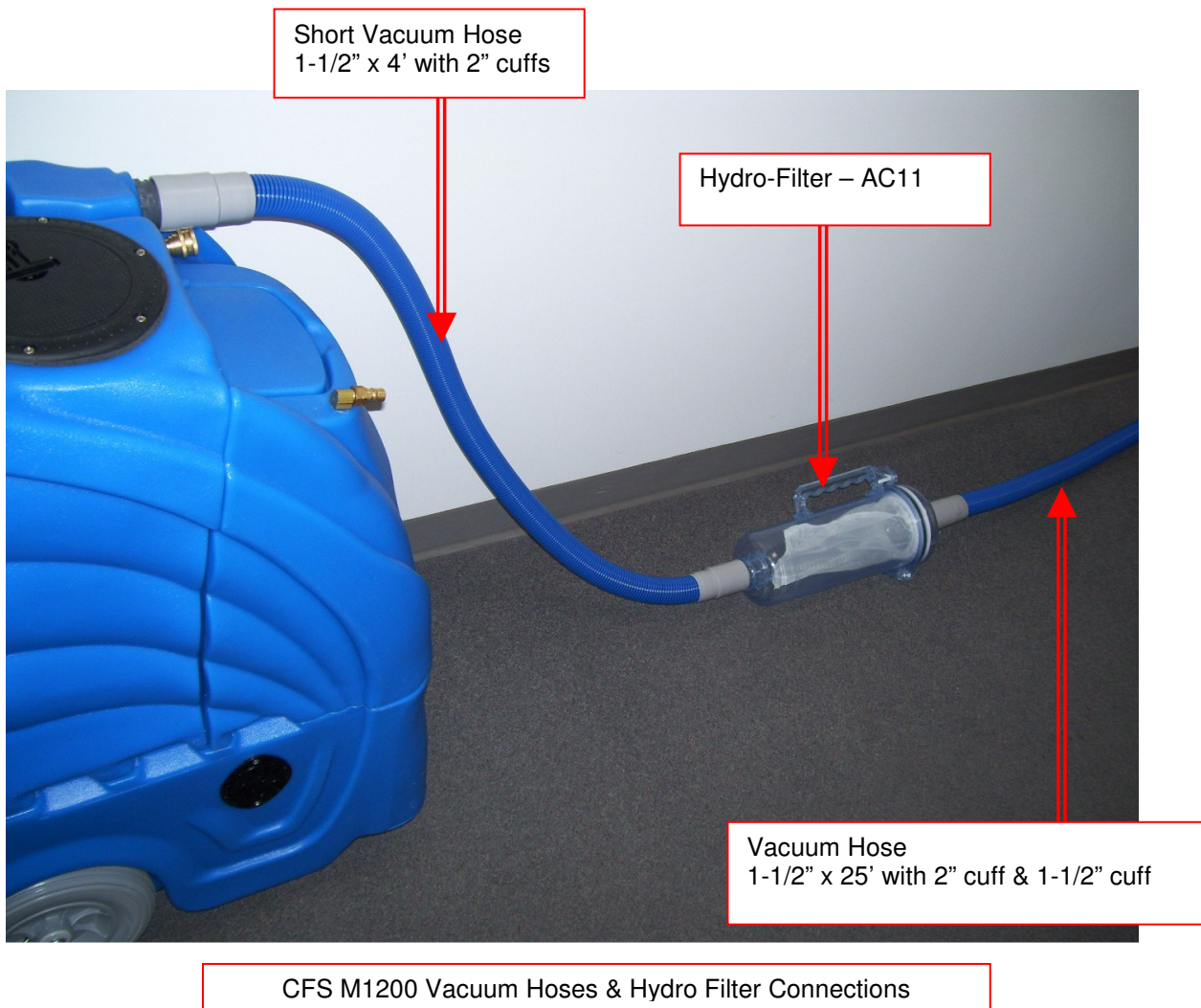

Foam Downer:

A key problem with portable extractors is that they have small tanks where foam dissipates slowly. If you have had issues with foam or are anticipating foaming problems, you will want to setup your Foam Downer.

Foam can be drawn into the vacuums without the pump-out turning on or before the vacuum shutoff closes. Foam and water blowing out the vacuum makes a big mess, can decrease vacuum lift and damage the vacuum motors.

The Foam Downer kills foam as waste water enters the machine. Use a strap or Hose Hook (Not included) to hang a jug of liquid defoamer on the front of your CFS M1200. The vacuum air flow siphons the liquid defoamer through Foam Downer into the vacuum tank, breaking down the foam before it can cause any damage or make a mess.

- Mounts and is ready to use in seconds
- Uses defoamer very economically
- NO LABOR is involved to spray or spread defoamer – it's all automatic
- Keeps silicone defoamers off the floor where they can cause resoiling problems

The Foam Downer is an attachment that allows the vacuum to draw a small amount of defoamer in a constant slow flow into the waste tank of the CFS M1200. We recommend using a diluted defoaming solution of four ounces of concentrated liquid defoamer to one gallon of water (1-32). Place the draw tube into the gallon of diluted defoamer and open the needle valve one half turn as your starting point. If this is not sufficient to break down the foam you can open the valve more or add more defoamer to the water to make a stronger solution.

With the valve open one half turn it will take approximately one half hour to drain the gallon of diluted defoaming solution.

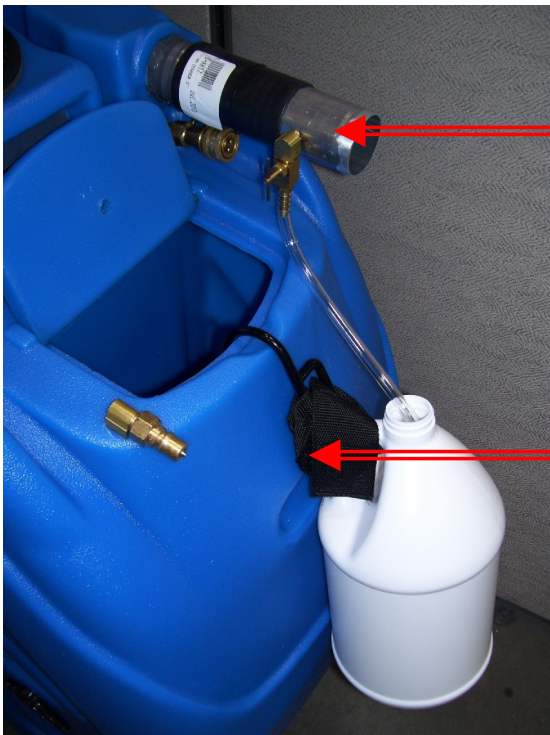

FOAM
DOWNER



Hose Hook
AH95



FOAM-LESS - CH47GL
Concentrated Liquid
Defoamer

6. Connection of Pump-out Hose:

The pump-out hose is a 50' section of 3/4" garden hose.

- Remove the cap from the pump-out outlet fitting on the back of the machine.
- Connect the pump-out hose to the outlet fitting.
- Place the other end of the hose in a commode or drain connected to the sanitary sewer system.
- Secure hose end to prevent movement during pumping.

Use defoamer to prevent foam build-up in recovery tank during cleaning and to keep foam/moisture from entering vacuums.

When ready to begin cleaning, turn the waste pump switch to the ON position.

- **Do not turn on waste pump switch unless pump-out hose is connected and has been routed to a proper drain.**



Pump-out Hose – AH65
3/4" id X 50' with M-F Garden Hose Fittings

Connect the Female Garden Hose Fitting end of the Pump-out Hose to the outlet fitting on the back of the recovery tank. Place the other end of the pump-out hose in a sanitary drain.

If not using the waste pump-out, the pump-out hose does not need to be connected. When the recovery tank fills during cleaning, the float ball assembly in the vacuum inlet filter will rise and will automatically shut off the vacuum air flow to prevent the recovery tank from overflowing and waste water from getting into the vacuums. When this occurs:

- Immediately shut off the vacuum switches.
- Drain the recovery tank.
 - Turn off the pump switch while draining the tank.
 - Turn pump switch back upon resumption of cleaning.
- Close the drain valve and turn the vacuum switches back on when ready to resume cleaning.

If the pump-out or vacuum shutoff is not working properly, refer to the trouble shooting guide or contact your distributor for advice or assistance.



Float Shutoff Assembly – NM5037



Draining the Recovery Tank

7. Pressure Adjustment:

When the high-pressure solution pump is on and primed, pressure will show on the gauge only while the tool is being sprayed. **When the tool is sprayed the gauge will display the pressure being delivered to the tool. When the tool is not being sprayed the gauge will return to zero.**

- To decrease the pressure, turn the black knob on the pressure regulator to the left (counter-clockwise.)
- To increase the pressure, turn the black knob on the pressure regulator to the right (clockwise.)
- To adjust pressure to your tool and surface requirements:
 - Spray the tool.
 - Check the pressure on the gauge.
 - Re-adjust as needed to set the machine at the desired pressure.
 - Choose the pressure setting that best meets your type of cleaning.



To increase the solution pressure, turn the regulator knob clockwise.

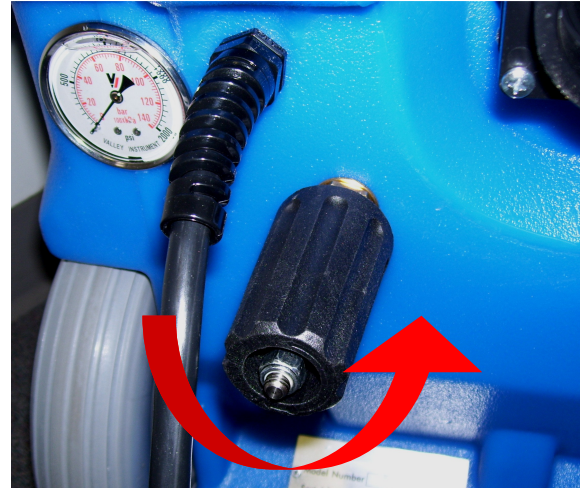

To decrease the solution pressure, turn the regulator knob counter-clockwise.

The maximum pressure setting is 1200psi; however, the highest pressure attained is dependent on the amount of water flow at the tool:

- Smaller jets and lower flow will allow for higher pressure at the tool.
- Larger jets and higher flow will lower the maximum pressure attained at the tool.

The desired setting will depend on the type of cleaning and tool used. For example:

- Carpet Cleaning with 2-jet AW29 wand: 400psi
- Tile Cleaning with SX-12: 1000psi

If adjusting or maintaining pressure becomes a problem, refer to the trouble shooting guide or contact your distributor for advice or assistance.



Pressure gauge

Shutdown Procedures:

- If using the auto-fill system, turn the water supply off before finishing each job. This will allow use of the water and chemical already in the tank, and will reduce the amount of excess water to be disposed of later.
- When finished cleaning, turn off all switches.
- If the auto-fill system was used and there is still water in the solution tank, turn off the faucet and push the float down to release the water inlet hose pressure before disconnecting the hose from the faucet. Disconnect the water inlet hose from the quick-connect on the front of the machine.
- Disconnect the solution hose and vacuum hose from the cleaning tool. Pull valve trigger to release pressure from the hose before disconnecting solution hose from cleaning tool.

- Disconnect the Hydro-Filter from the vacuum hoses and clean the filter as needed. Replacement filter bags are available (AC11A.)
- Disconnect the vacuum hose and solution hose from the machine.



- If water remains in the solution tank, use the short vacuum hose and vacuum the excess water from the tank.
- If the auto-fill system was utilized, place the chemical feed hose back into the solution tank.
- If the waste pump-out system was used:
 - Turn the waste pump switch “on” to pump out any remaining water from the recovery tank.
 - Turn switch off, remove the pump-out hose from the outlet fitting and replace the cap.
 - Roll up hose toward drain to remove remaining water from hose.
 - Connect ends of hose together to prevent dirty water from dripping from hose during transport.

- Disconnect the power cords from the outlets and from the machine.

- Remove the float shutoff assembly from the recovery tank and clean filter as needed. Replace shutoff assembly and tank lid.



- Drain any remaining water from the recovery tank and dispose in sanitary drain. Do not use the same bucket to drain the tank that you use to fill the tank.

- Roll up all hoses and cords. Collect and store extractor, all tools, and accessories.



Troubleshooting – CFS M1200

Problem	Cause	Solution
Machine not turning on - No power	Building circuit breaker tripped.	Reset breakers or move cords to other outlets
	Power Cord GFCI tripped	Reset GFCI
	Faulty power cord or GFC1	Replace cord (NM4407)
	Faulty switches or internal wiring	Check wiring & test switches - Repair as needed *
Solution Pump not running	Building circuit breaker tripped.	Reset breakers or move cords to other outlets
	Power Cord GFCI tripped	Reset GFCI
	Faulty power cord or GFC1	Replace cord (NM4407)
	Water Level too low	Raise solution tank water level to engage float switch
	Float Switch stuck or defective	Free float switch or replace as needed
	Faulty switches or internal wiring	Check wiring & test switches - Repair as needed *
	Float Relay Defective	Replace Relay
	Pump motor breaker tripped	Push in reset button on pump motor
	Pump motor faulty	Replace pump motor (PT059)
	Pump seized - trips breaker	Repair or replace pump head & bearing (PT058) - Check motor and/or replace complete pump & motor assy. (AP48)
Low Solution Pressure or Pulsation	Jets too large for pressure desired	Check jets size & flow rates use smaller jets or lower pressure
	Jets worn allowing too much flow	Replace jets
	Solution inlet filter plugged	Clean or replace filter
	Hose from solution tank restricted	Repair or replace hose
	Pump intake hose / fittings leaking	Repair or replace hose. Tighten clamps or replace fittings
	Pressure regulator sticking	Lube o-rings on regulator shaft
	Pressure regulator faulty	Repair or replace pressure regulator (PT019A or PT019)
	Filter screen or jets plugged on tool	Clean out filter or jets
	Solution tank empty	Add water to tank - Check & repair auto fill assembly
	Pump not primed	Perform pump priming procedure
	Pump faulty	Repair or replace pump (PT059 or AP48)
	Pressure Gauge faulty	Replace gauge (PT063)
	Tool valve faulty	Repair or replace valve
	Quick connects or hoses restricted	Clean out or replace quick connects and/or hoses
Can't connect solution hose to machine	Pressure in lines	Release pressure
	Quick connects faulty	Replace quick connects (100008, 100007)
	Wrong style/size quick connects	Replace quick connects to match connects on machine
<p>* To reduce the risk of fire electrical shock or injury, repairs to wiring should only be performed by experienced service technicians. If you are not experienced in checking electrical wiring contact your nearest authorized service center to perform tests and repairs to wiring and switches.</p>		

Problem	Cause	Solution
Pump-out not working	Building circuit breaker tripped.	Reset breakers or move cords to other outlets
	Power Cord GFCI tripped	Reset GFCI
	Faulty power cord or GFC1	Replace cord (NM4407)
	Faulty switches or internal wiring	Check wiring & test switches - Repair as needed * (NM5008)
	Pump-out pump faulty	Replace pump-out pump (NM5053)
	Pump-out pump clogged	Clean pump-out - Keep recovery tank clean - Use Hydro-Filter
	Outlet check valve stuck	Clean or replace check valve
	Discharge hose restricted	Un-kink, clean out or replace hose
	Float switch stuck	Clean switch make sure float slides up & down easily
	Float switch faulty	Replace float switch (NM5054)
Vacuum Motor not running	Building circuit breaker tripped.	Reset breakers or move cords to other outlets
	Power Cord GFCI tripped	Reset GFCI
	Faulty power cord or GFC1	Replace cord (NM4407)
	Faulty switches or internal wiring	Check wiring & test switches - Repair as needed *
	Vacuum motor faulty	Replace vacuum motor (AV010, AV14)
Loss of Vacuum	Vacuum motor faulty	Replace vacuum motor (AV010, AV14)
	Vacuum motor gasket damaged	Replace gasket (PA010)
	Recovery tank lid gasket damaged	Replace gasket (NM5059)
	Drain valve open	Close valve
	Drain valve leaking	Repair or replace drain valve (PEA11)
	Vacuum motor hoses loose / leaking	Reconnect or replace vacuum motor hoses
	Vacuum hose or tool clogged	Clean out vacuum hoses and tool
	Vacuum hoses or cuffs leaking	Replace vacuum hoses, cuffs & connectors as needed
	Recovery tank full	Drain tank
	Float shutoff filter clogged	Clean float shutoff filter
	Ball stuck in float shutoff	Repair or replace float shutoff (NM5037)
	Pump-out Check Valve stuck open	Clean out or replace check valve (NM5052)
	Recovery tank damaged	Replace recovery tank
Chemical not feeding	Solution tank not filling	Check & repair auto fill assembly
	Chemical hose restricted	Un-kink, shorten, clean out or replace hose
	Filter screen plugged	Clean or replace filter (PDE100-11P)
	Low Incoming Water Pressure	Set chemical bottle on top of machine – Shorten Chemical hose – Find other water source.
	Wrong size metering tip	Change metering tip
	Chemical proportioner faulty	Replace chemical proportioner (PDE61-22-3)
	Check valve in filter faulty	Replace filter (PDE100-11P)
Tool won't spray - low or uneven spray	Jets clogged	Clean out or replace jets
	Inline filter clogged	Clean out or replace filter
	Jets worn	Replace jets
	Jets not aligned properly	Re-align jets
	Tool valve faulty	Repair or replace valve
	Quick connects or hoses restricted	Clean out or replace quick connects and/or hoses
<p>* To reduce the risk of fire electrical shock or injury, repairs to wiring should only be performed by experienced service technicians. If you are not experienced in checking electrical wiring contact your nearest authorized service center to perform tests and repairs to wiring and switches.</p>		

Problem	Cause	Solution
Solution Tank not filling	Water source turned off	Turn on faucet or find other water source
	Water hose restricted	Un-kink, clean out or replace hose
	Float valve faulty	Repair or replace float valve (NM5055)
	Float not on valve hanger	Reconnect float to valve hanger - Adjust chain to set float to proper height/level
	Quick connects faulty	Clean out or replace quick connects (100008, 100007)
Solution tank overflowing	Float too heavy/ Filled with water	Replace float (PHY005-003)
	Float & chain tangled	Make sure float chain free & hanging properly
	Float too high	Adjust chain to set float at proper level
	Float valve faulty	Repair or replace float valve (NM5055)
	Water Supply Pressure too high	Close valve to reduce pressure or use inline pressure reducer / regulator to limit supply pressure
Chemical Jug Filling with Water - Overflowing	Foot valve in Filter stuck	Clean out foot valve and filter
	Foot valve in Filter faulty	Replace foot valve and filter (PDE100-11P)
<p>* To reduce the risk of fire electrical shock or injury, repairs to wiring should only be performed by experienced service technicians. If you are not experienced in checking electrical wiring contact your nearest authorized service center to perform tests and repairs to wiring and switches.</p>		

- Contact HMS Manufacturing LLC for additional troubleshooting assistance, to order parts, or for advice and assistance in performing necessary repairs.

CFS M1200

Solution Flow Path

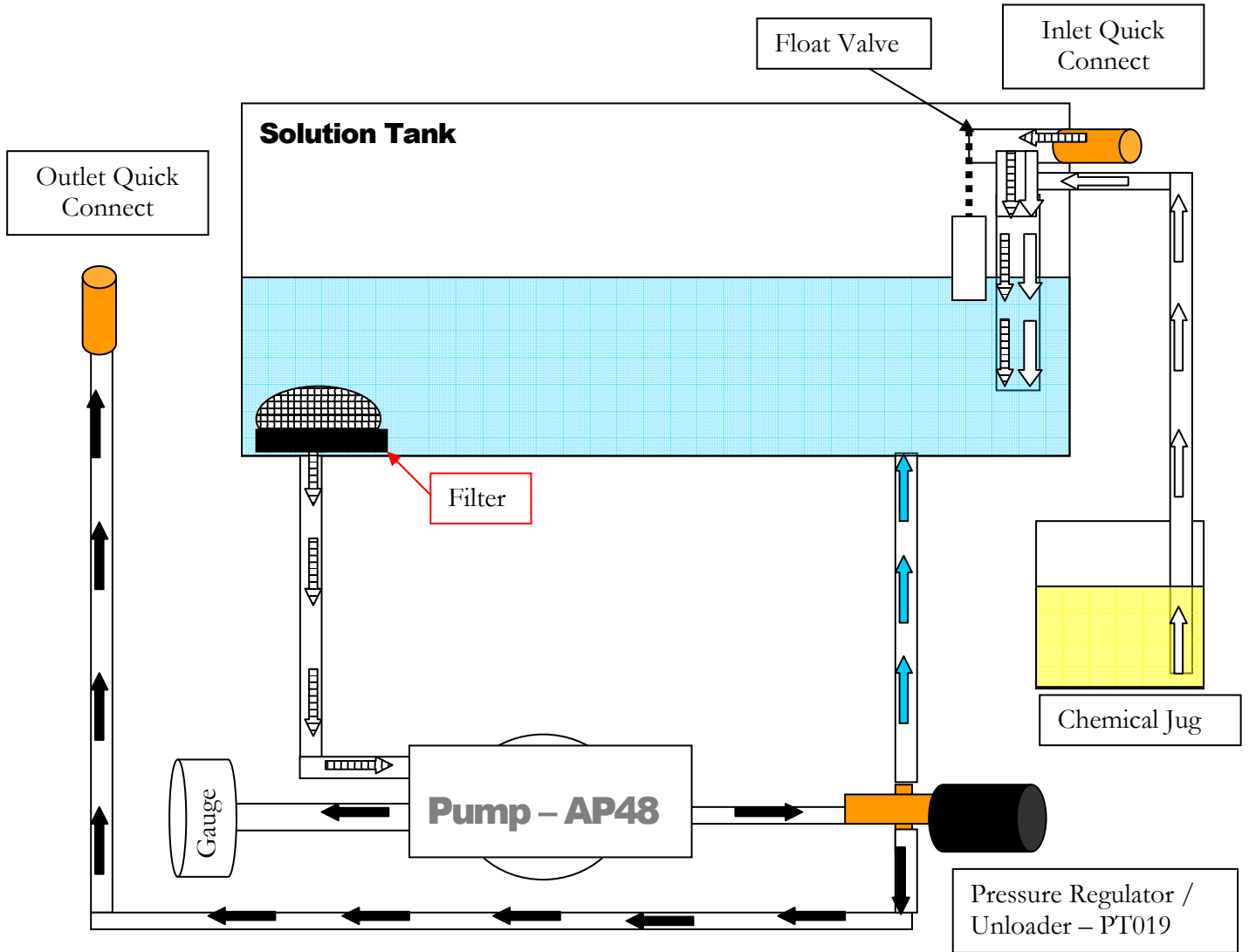

Denotes incoming water flow

Denotes Water flow in high pressure hose

Denotes by-pass water flow from pressure regulator

Denotes Chemical flow

CFS M1200 Wiring

Indicator Light
NX201

- The black wire from cord #1 connects to the first white wire of the Breaker Buddy circuit board.
- The white wire from cord #1 connects to the first black wire of the Breaker Buddy circuit board.
- The black wire from cord #2 connects to the second white wire of the Breaker Buddy circuit board.
- The white wire from cord #2 connects to the second black wire of the Breaker Buddy circuit board.

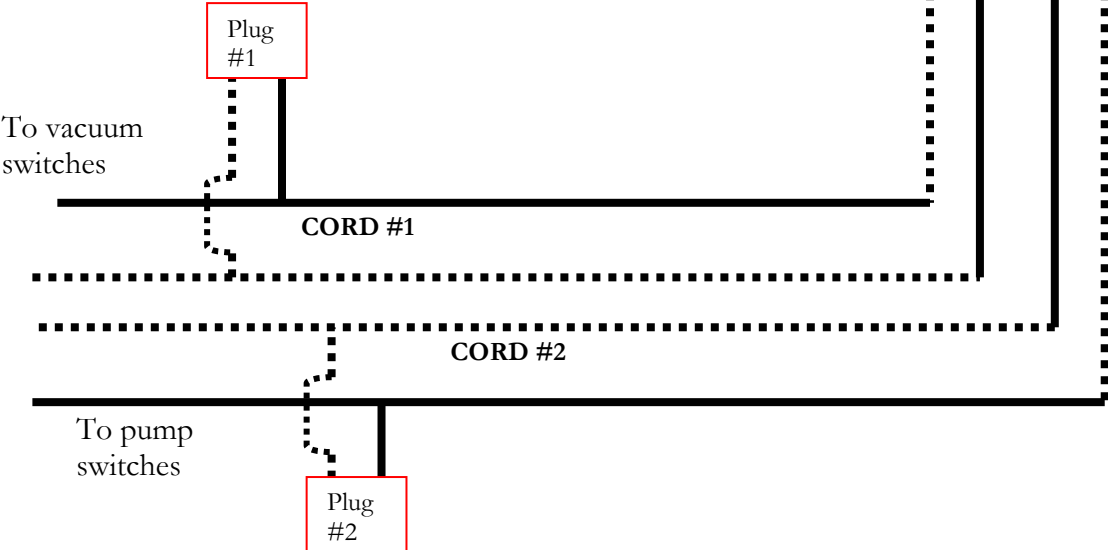
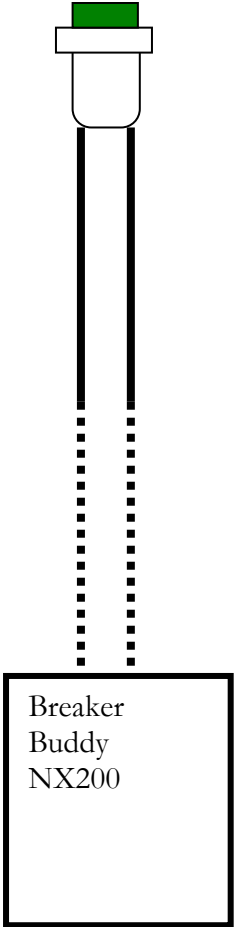

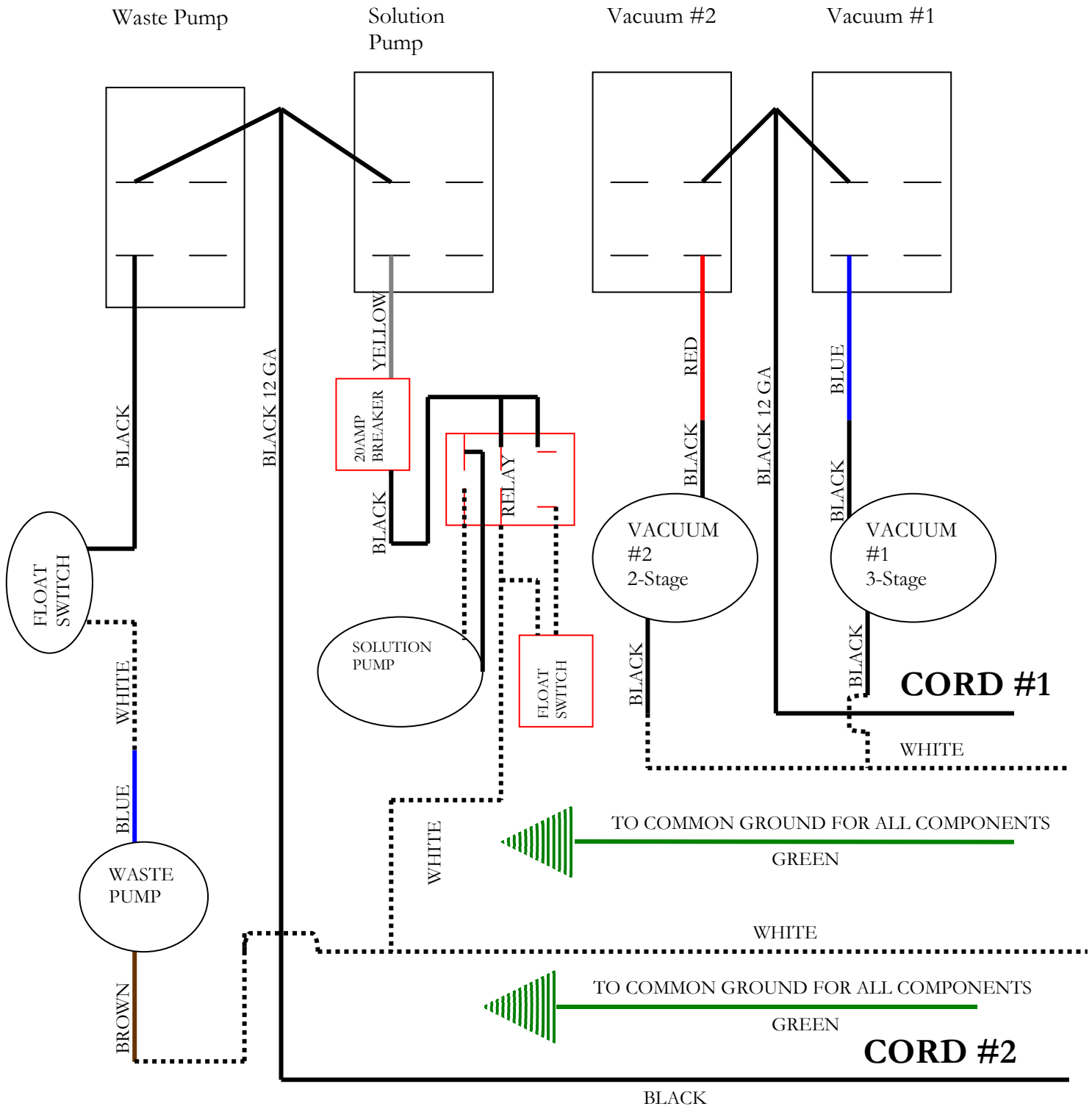

CFS M1200 SWITCH PANEL:



Vacuum #1 – Power from Cord #1.
When the switch is turned to the ON position power is supplied to the vacuum motor. (3-Stage Vacuum)

Vacuum #2 – Power from Cord #1.
When the switch is turned to the ON position power is supplied to the vacuum motor. (2-Stage Vacuum)

Solution Pump Switch – Power from Cord #2.
When the switch is turned to the ON position power is supplied to the solution pump motor. When not using solution (Extracting Only) do not turn this switch ON.

Waste Pump Switch – Power from Cord #2.
When switch is turned to the ON position, Waste Pump operation is controlled by the Float Switch in the Recovery Tank. Pump will remain off until water level rises to the point at which the float switch will turn the Waste Pump ON. Do not turn Waste Pump Switch ON unless a hose is connected to the Pump-out Outlet port.

Maintenance

Proper maintenance is required to keep the CFS M1200 operating properly, prevent downtime and to extend the life of your equipment.

WARNING: Disconnect electrical power before performing any service or maintenance inside machine base or before testing or repairing switches or power cords. Failure to do so may result in severe personal injury or death.

OPERATION	INTERVAL	Page #
CLEAN CHEMICAL FEED FILTER & FOOT VALVE	Daily – After Each Job	27
CLEAN VACUUM SHUTOFF ASSEMBLY SCREEN	Daily – After Each Job	27
CLEAN HYDRO-FILTER	Daily – After Each Job	28
RINSE OUT RECOVERY TANK	Daily	28
CLEAN WASTE PUMP-OUT PUMP	Daily	29
FLUSH SOLUTION TANK AND PUMP	Daily	29
CLEAN PUMP-INLET FILTER	Weekly – As needed	30
FLUSH CHEMICAL SYSTEM	Monthly	31
LUBRICATE PRESSURE REGULATOR O-RINGS	Monthly	32
CLEAN DRAIN VALVE	As needed	34
STORAGE PREP – FREEZE PROTECTION	As needed	35

CLEAN CHEMICAL FEED FILTER & FOOT VALVE:

The Filter & Foot Valve is on the end of the chemical feed hose that is placed in the chemical jug as part of the chemical feed system.

Regularly examine the filter and clean as needed.

To test the Foot Valve:

- Remove the Filter & Foot Valve from the end of the chemical feed hose and rinse in fresh water.
- Blow through the valve from the filter side of the barb.
 - If the Foot Valve is functioning, air should move freely from the filter side, but will not flow from the barb side of the filter.
 - If valve is not functional, clean or replace as needed.

Heavy chemical build-up can be removed with a mild acid rinse and/or the use of a brush and compressed air.

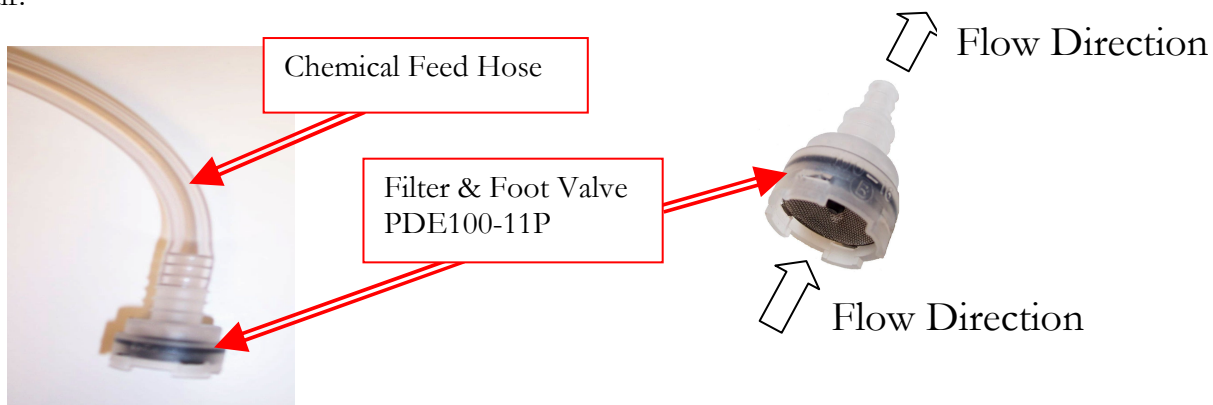

CLEAN VACUUM SHUTOFF ASSEMBLY SCREEN:

Inside the recovery tank, on top of the stand pipe, is the Vacuum Shutoff Assembly. It functions to prevent debris and water from being sucked into the vacuum motors. Operating the CFS M1200 without the Vacuum Shutoff Assembly or with a poorly maintained assembly will greatly decrease the life of the vacuum motors and will void the warranty.

If debris builds up on this filter, it will reduce the vacuum air flow and may cause a significant decrease in the rate of water recovery. If debris prevents the float ball from moving or seating inside the assembly, it may not stop the airflow when the tank fill with water, and the water will be sucked into the vacuums and blown out the exhaust. **Use defoamer to prevent foam or moisture from entering vacuums.**

To clean:

- Twist to loosen and pull the assembly off of the stand pipe.
- Pull fibers and lint off and rinse with clean water.
- Push the assembly back onto the stand pipe and replace the recovery tank lid.



Vacuum Shutoff Assembly
NM5037



CLEAN THE HYDRO-FILTER:

Build-up of debris in the filter bag of the Hydro-Filter will reduce the vacuum air flow and may cause a significant decrease in water recovery. A torn filter bag will allow debris past the filter and into the recovery tank. This debris can clog the Waste Pump and the Vacuum Shutoff Assembly. **The Hydro-Filter must be examined and cleaned regularly to keep the CFS M1200 functioning properly:**

- Push the latch lever and open the Hydro-Filter lid.
- Remove the filter bag. Examine the bag and clean or replace as needed.
- Rinse the body of the Hydro-Filter with clean water.
- Examine the o-ring seal and replace as needed.
- Re-install the new or cleaned bag.
- Close lid and secure latch.

Repair parts are available for the Hydro-Filter:

Filter Bag: AC11A

Parts Kit: AC11B – (Includes Latch, O-ring & screws.)

Lid: AC11D

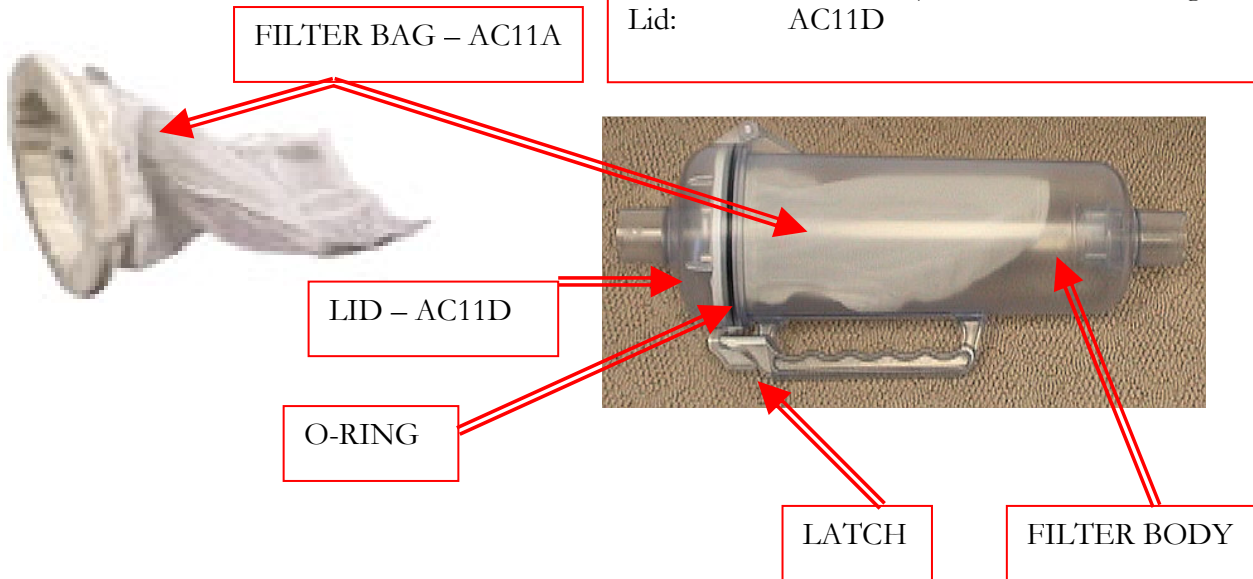

RINSE OUT RECOVERY TANK:

Build-up of fine silt and debris can damage the Waste Pump and Drain Valve. Clean out the tank on a regular basis to extend the life of these components as well as keep the tank and machine smelling better.

- Remove the recovery tank lid and open the drain valve.
- Place a bucket under the drain valve.
- Use a hose to rinse the dirt and debris out of the recovery tank.
- Close the drain valve and spray the tank with a deodorizer or disinfectant.
- Proceed to Waste Pump Cleaning and replace the recovery tank lid.
- Dispose of the dirty water and debris.



CLEAN WASTE PUMP-OUT PUMP:

Build-up of fine silt inside the Waste Pump can clog the pump even if the pump is not used, so this maintenance procedure should be performed regardless of whether the Waste Pump has been used.

- After cleaning out the recovery tank, remove the cap and connect the Pump-Out hose to the Waste Pump outlet fitting on the back of the machine; run the hose to a drain.
- With Cord #2 plugged in, turn the Waste Tank switch to the ON position.
- Use a hose to fill the recovery tank to the point where the float switch turns the Waste Pump ON.
- Let the pump run until it pumps the level down to the point when the float switch shuts off the Waste Pump.
- Unplug the cord and turn the Waste Pump switch OFF.
- Open the drain valve and drain out the remaining water.
- Close the drain valve, replace the recovery tank lid, and dispose of the dirty water and debris.

FLUSH SOLUTION TANK AND PUMP:

- Pour two or three gallons of clean water into the solution tank. Add enough water to lift and engage the float switch.
- With Cords #1 & #2 plugged in, connect the pump prime hose to the solution outlet female quick connect.
- Turn one or both of the vacuums ON and turn the solution pump ON.
- Block off the vacuum port and push & hold the priming valve.
- Let the pump run until most of the water has been pumped out of the solution tank. **Do not let the pump run dry. If the float switch does not shutoff the pump, turn the pump OFF before the water gets to the bottom of the tank.**
- Turn the vacuums OFF and release the priming valve.
- Place a bucket under the drain valve; open the drain valve to drain the water out of the recovery tank.
- Close the drain valve and dispose of the water.



Pour 2 or 3 gallons of clean water into Solution Tank

If there is a heavy chemical build-up in the machine, hoses, or tools, a mild acid can be added to the rinse water in the previous procedure (REFER TO PHOTOS ON FOLLOWING PAGE.)

- After the pump has been primed, turn the solution pump switch OFF and turn the vacuums OFF.
- Connect the HP solution hose and tools.
- Turn the solution pump ON and direct the tool spray into a bucket. Let the pump run until most of the water has been pumped out of the solution tank. **Do not let the pump run dry. If the float switch does not shutoff the pump, turn the pump OFF before the water gets to the bottom of the tank.**
- Disconnect the solution hose and tool.
- Use the 4' short section of vacuum hose to vacuum the remaining acid out of the solution tank.
- Pour two or three gallons of clean water into the solution tank.
- Turn one or both of the vacuums ON and turn the solution pump ON. Block off the vacuum port and push & hold the priming valve. Let the pump run until most of the water has been pumped out of the solution tank. **Do not let the pump run dry. If the float switch does not shutoff the pump, turn the pump OFF before the water gets to the bottom of the tank.**
- Turn the vacuums OFF and release the pump priming valve.
- Place a bucket under the drain valve and open the drain valve to drain the water out of the recovery tank.

- Close the drain valve and dispose of the water.

FLUSH SOLUTION TANK AND PUMP: (continued from previous page)



Push & hold the pump priming valve



Vacuum acid solution out of Solution Tank

CLEAN PUMP INLET FILTER

A restricted Pump Inlet Filter can prevent the solution pump from providing adequate pressure for cleaning. A restriction or air leak on the pump inlet hose can also damage the solution pump check valves and plunger seals.

CAUTION: Before proceeding with this procedure, make sure both power cords are disconnected.

- To examine the filter, open the solution tank lid on the front of the machine. The filter is in the bottom of the solution tank.
- Grasp the filter cap and unscrew the filter from the brass nipple by turning counter-clockwise. Clean or replace the filter as needed (PP14-806504).
- To examine the pump inlet hose, release the latch on the front of the machine and tilt the tanks off of the base assembly. Support the tanks with a chair, bucket or box while working inside the base.
- Examine the hose for kinks, clogs or holes and repair or replace the hose as needed. (Replacement Hose: NM5086 – sold per foot)
- Tilt the tanks back onto the base and secure the latch.

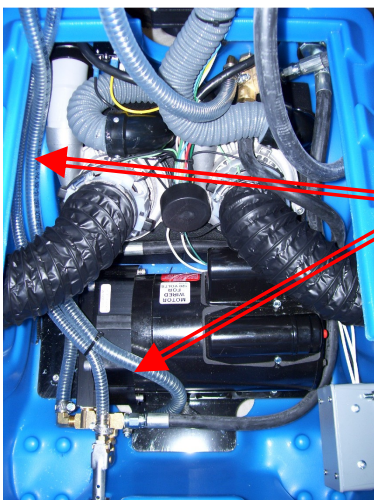
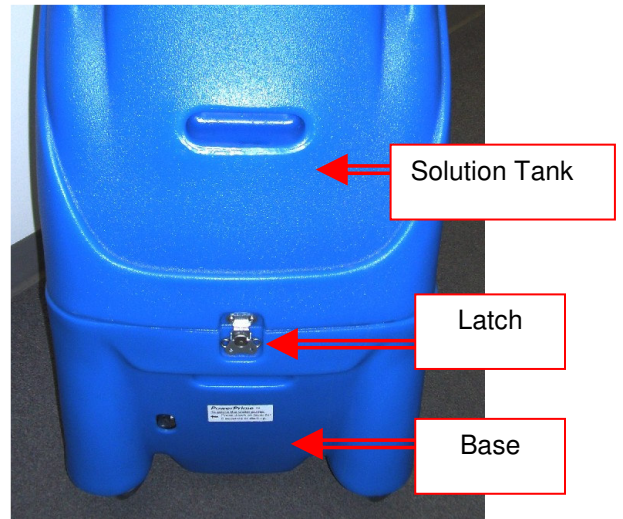

PUMP INLET HOSE
NM5086

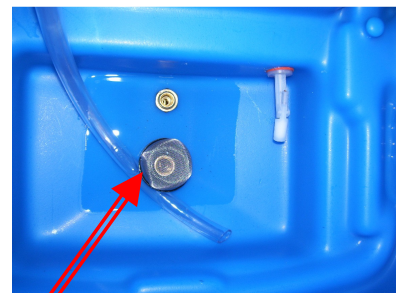

SOLUTION FILTER
PP14-806504



FLUSH CHEMICAL SYSTEM:

Chemical build-up in the chemical system can prevent the system from drawing chemical.

- Rinse the chemical system with fresh water (For heavy chemical build-up, a mild acid can be added to the rinse water.)
- Remove the chemical feed hose from the solution tank and place the end of the hose in a bucket of fresh water or mild acid solution.
- Connect the Auto-Fill Water Supply Hose to the water inlet (male quick connect) on the front of the machine.
- Connect the other end of the hose to a water faucet and turn on the water. Let the water flow into the tank until you are sure the rinse solution has been drawn through the proportioner and mixed with the incoming water. The metering tip can be removed from the proportioner to speed up the process.
- Once the rinse solution has been drawn through the proportioner, turn off the water faucet and disconnect the Auto-Fill Water Supply Hose.
- Plug in Cord #1, connect the short 4' vacuum hose to the vacuum barb, turn on one or both vacuums, and use the short vacuum hose to remove the water from the solution tank.
- When the solution tank has been emptied, turn off the vacuums and unplug the power cord.
- Place a bucket under the drain valve and open the drain valve to drain the water from the recovery tank.
- Close the drain valve and dispose of the water.



Place Chemical Feed Hose into Rinse Solution



Connect Auto-Fill Water Supply Hose to machine and faucet



Vacuum water out of Solution Tank



Drain water from Recovery Tank

LUBRICATE PRESSURE REGULATOR O-RINGS:

To maintain consistent adequate pressure delivery to the cleaning tool, the o-rings on the stem of the CFS M1200 pressure regulator must be lubricated regularly.

1. Remove nut from the end of the regulator stem.
2. Remove the black knob from the regulator stem.
3. Remove the spring plate, spring, and spring washer from the regulator stem.
4. Remove the jam nut and washer from the shoulder of the regulator stem retainer. (The set point nuts do not need to be removed.)

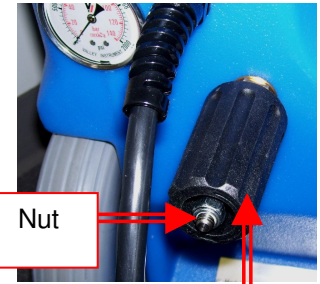

Nut

Black Knob

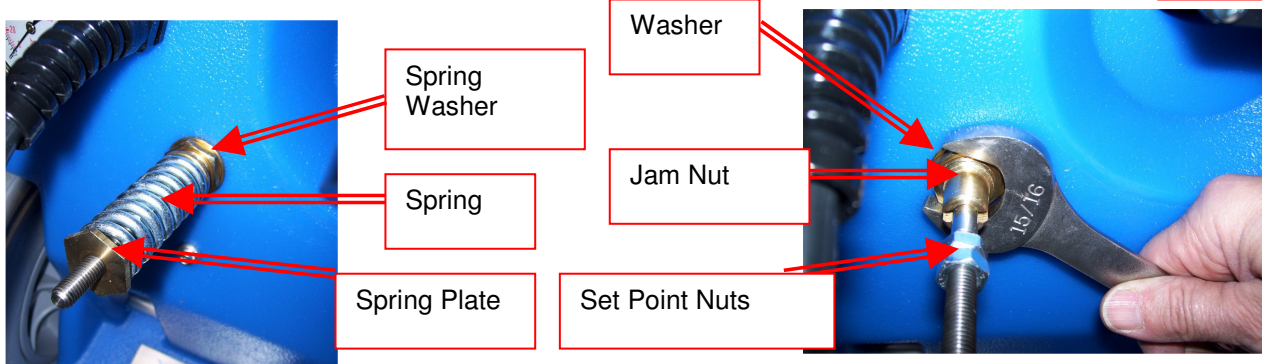

Washer

Spring Washer

Spring

Spring Plate

Jam Nut

Set Point Nuts

5. Release the latch on the front of the machine and tilt the tanks off of the base assembly. **Support the tanks with a chair, bucket, or box while working inside the base.**
6. Disconnect the vacuum hose from the vacuum manifold and move it out of the way to gain access to the regulator.
7. Pull the regulator assembly from the base wall opening (back into the base) to access the regulator. A hose may have to be disconnected to move the regulator into a better working position.
8. Hold the body of the regulator with a wrench or vice-grip pliers. Use another wrench to loosen and remove the stem retainer, then remove the stem assembly from the body of the regulator.



LATCH



Loosen & remove Stem Retainer from regulator body

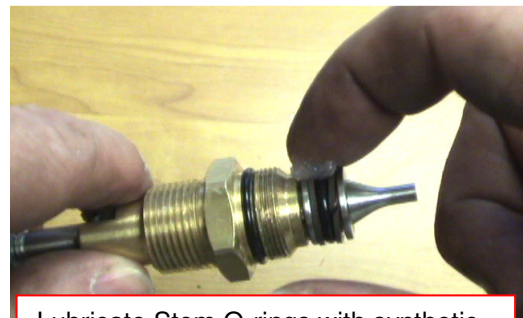

Lubricate Stem O-rings with synthetic grease

9. Use a synthetic grease with Teflon such as Ultra-Slick or Super-Lube to lubricate the o-rings on the regulator stem.

10. Apply thread sealant to the threads of the stem retainer and screw the retainer back into the regulator body. Tighten using wrenches.

Apply thread sealant to stem retainer

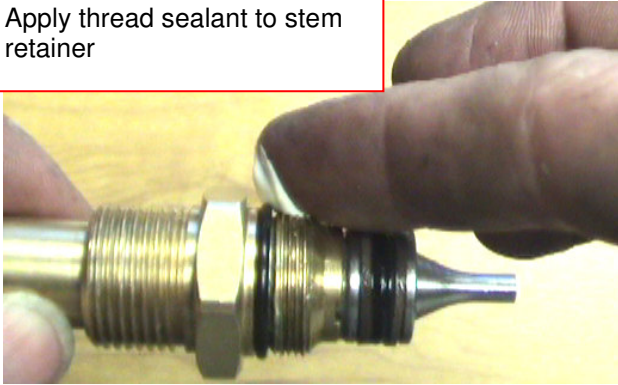

Screw stem retainer back into regulator body

11. Place the regulator back into the opening on the base wall. Reconnect any hoses which were removed to access the regulator. (Use thread sealant when reconnecting hoses.)
12. Reconnect vacuum hose to vacuum manifold.

Regulator – Inserted into opening on base wall

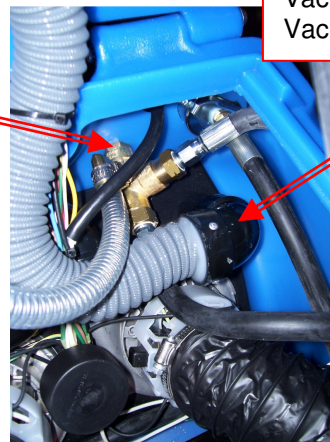

Vacuum Hose – Connected to Vacuum Manifold

13. Close tanks back onto base and secure latch.
14. Place washer and jam nut back onto shoulder of regulator and tighten to secure regulator to base wall.
15. Replace spring washer, spring, and spring plate back onto regulator stem.
16. Screw black knob back onto regulator stem.
17. Screw nut back onto regulator stem. Do not screw nut on too far, as the nut may interfere with the movement of the regulator knob and prevent the knob from being backed out when trying to adjust regulator to lower pressures.



CLEAN RECOVERY TANK DRAIN

Debris and sand accumulation in the drain valve can damage the valve or prevent it from closing completely. This will result in dirty water leaking from the valve. Use of the Hydro-Filter and regular cleaning of the recovery tank will help prevent this, but occasionally the drain valve will require cleaning or replacement.

Drain the recovery tank before attempting to service the drain valve.

- Unscrew the nuts and remove the four bolts holding the valve assembly to the flange attached to the recovery tank. Unless the flange is damaged, it does not have to be removed from the tank, even when replacing the drain valve.
- Separate the valve body, outlet adapter and gaskets from the flange.

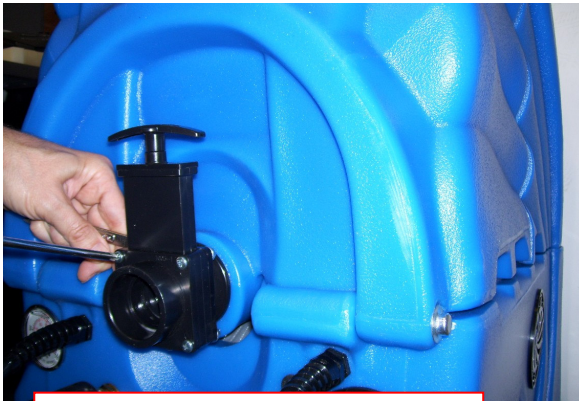

Remove four bolts holding valve assembly to flange fitting



FLANGE FITTING

Unless damaged or leaking between tank and flange, the flange fitting does not have to be removed



DRAIN VALVE – PEA11

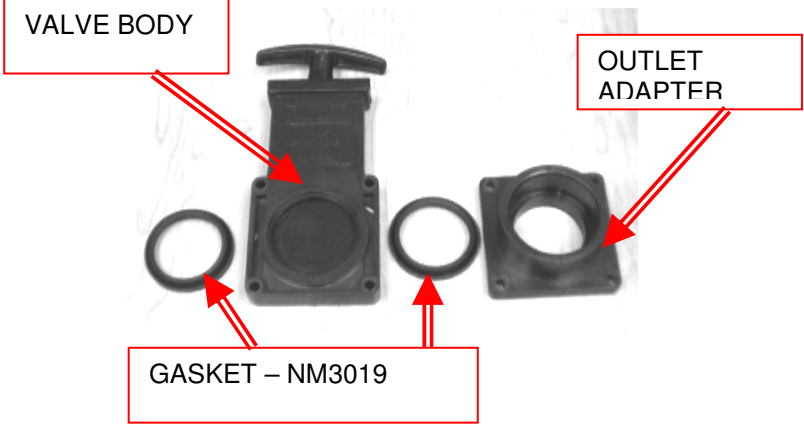

VALVE BODY

OUTLET ADAPTER

GASKET – NM3019

- Examine the valve body for wear. Check the valve slide for deep scratches. Deep scratches will allow water to flow past gaskets and leak from valve. Replace valve if needed.
- Examine the gaskets and replace if cut, torn or deformed.
- Raised, rounded side of gasket goes toward valve slide. Larger flat sides seat on ring on flange and outlet adapter. Sand and debris will collect in the bottom of the valve body and prevent the slide from going down and seating properly.
- Clean debris out as needed so slide can move to bottom.
- Rinse valve body and reassemble valve body, gaskets and outlet adapter, and place assembly back onto flange fitting.
- Replace four bolts and tighten evenly to secure assembly to flange. Do not over-tighten bolts.



Clean debris from slot in bottom of valve body. Valve slide must be able to slide to bottom.

Storage Prep and Freeze Protection Procedures:

Your CFS M1200 must be protected from freezing. Freezing can cause serious damage to the pump, pump-out, auto-fill float valve, and any other component containing water. If the CFS M1200 is transported or stored in freezing temperatures, the following procedures should be performed.

ALSO, if the CFS M1200 is stored for an extended period of time, the following procedure should be performed to prevent the pump seals from drying out.

1. In a separate container mix 1/2 gallon of water with 1/2 gallon of automotive radiator anti-freeze. (Ethylene glycol type). Mix well and pour into the solution tank. Mix and add more water/anti-freeze solution as needed to lift & engage float switch.
2. Perform the pump priming procedure. When the pump is primed, turn the pump off and release the pump priming valve.
3. Connect the HP solution hose to the solution outlet (female quick connect.) Connect the opposite end of the HP solution hose to the Auto-Fill inlet (male quick connect.) Leave the chemical feed hose in the solution tank and ensure the check valve filter is submerged in the anti-freeze solution. To speed the process the metering tip can be removed. Turn the pressure regulator knob counter-clockwise to lower the pressure to 100psi or lower
CAUTION: Applying high pressure (over 100psi) to the Auto-Fill system will cause damage to the Float valve and chemical proportioning mechanism.
4. Turn the solution pump switch to the ON position. If anti-freeze level in solution tank is not high enough to engage float switch, lift float switch up to operate solution pump. Allow the anti-freeze to circulate for 5-10 minutes. Mix and add more anti-freeze solution as needed. Make sure end of chemical feed hose stays submerged in the anti-freeze solution. This will assure that the anti-freeze will be drawn into the proportioning valve.
5. Connect any cleaning tools that will be stored with the CFS M1200. Direct tool spray back into the solution tank or into a bucket. Repeat for all tools to be protected.
6. Turn the solution pump switch to the OFF position.
7. Use the 4' short section of vacuum hose to vacuum the remaining anti-freeze solution out of the solution tank and bucket.
8. Remove the cap from the waste-pump out outlet fitting on the back of the machine. Connect a hose to a drain or hold a bucket up to the fitting to catch the pump-out flow.
9. Remove the lid from the recovery tank. Turn the Waste Pump switch to the ON position and lift the float switch to engage the pump-out. Lower the float and turn off the Waste Pump Switch as soon as you see anti-freeze flowing from the outlet fitting or hose.
10. Drain the remaining anti-freeze solution from the recovery tank and the machine is ready for storage.

RETURNING THE CFS M1200 TO SERVICE AFTER STORAGE OR FREEZE PROTECTION:

To return the CFS M1200 to service, the anti-freeze must be flushed from the machine. Flush the anti-freeze out of the machine by repeating the procedures above using fresh water in place of anti-freeze.

Parts

Replacement parts available for repair of your CFS M1200.

**CFS M1200 PUMP – AP48
PARTS ASSEMBLY**

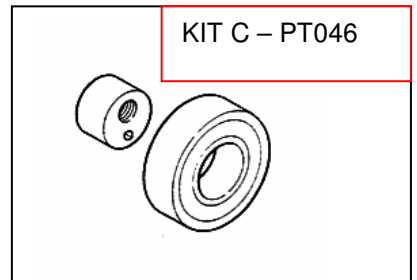
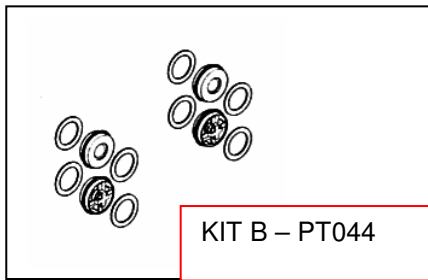
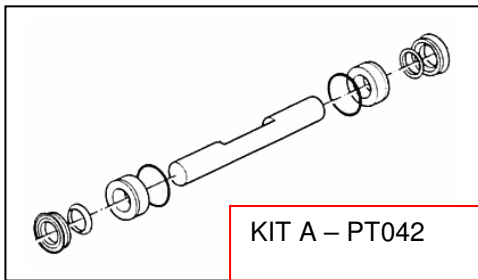
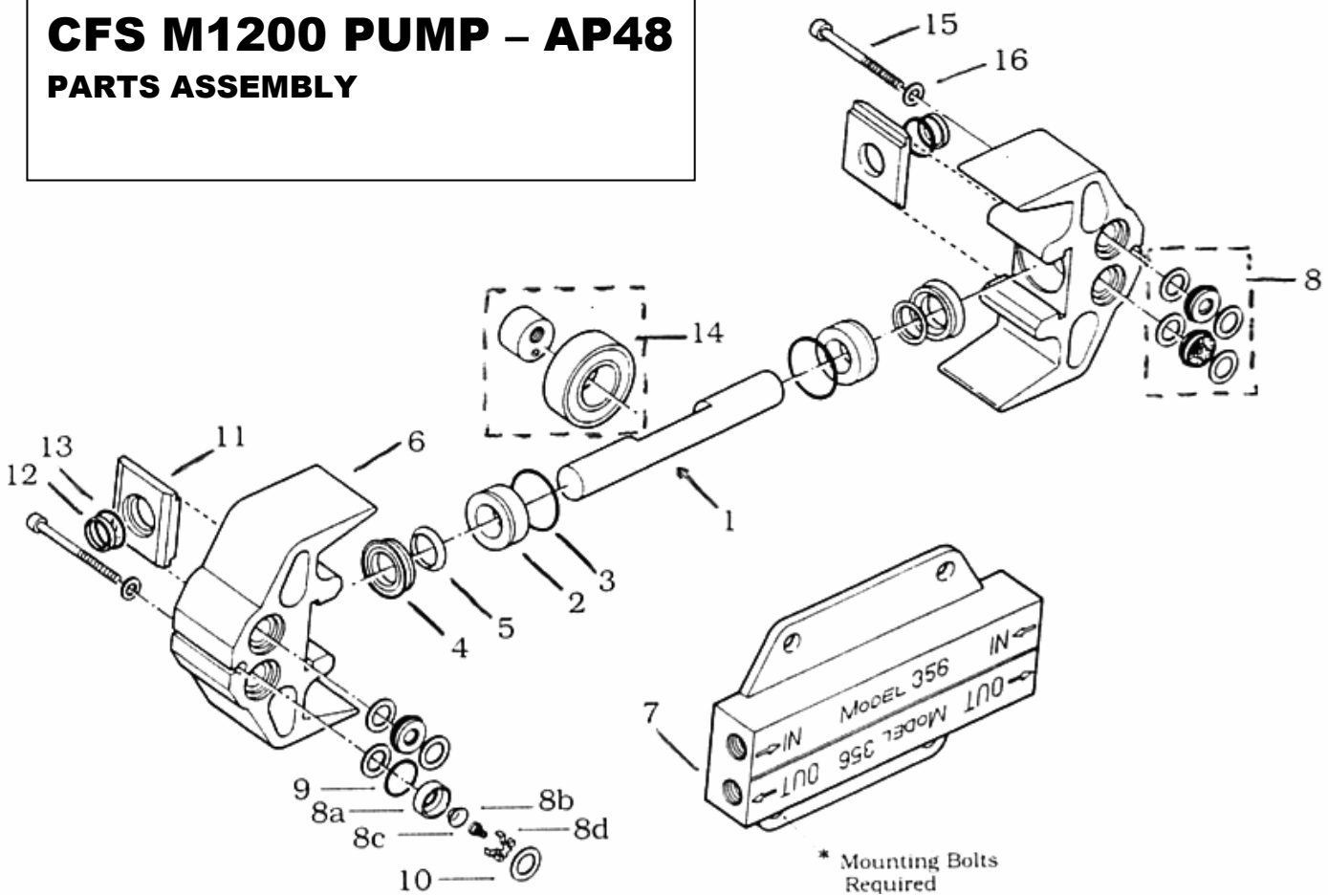

PUMPTEC #356 PUMP – AP48

ITEM	DESCRIPTION	QTY	PART NUMBER
1	PLUNGER	1	0311-0006-0002
2	PLUNGER GUIDE	2	0311-0009
3	O-RING FOR PLUNGER GUIDE	2	C0100-1124
4	U-CUP	2	C0220-1075
5	U-CUP BACKING RING	2	0311-0011
6	PUMP HEAD	2	0356-0002-0001
7	PUMP MANIFOLD	1	0356-0004-0001
8	VALVE ASSEMBLY	4	0205-0012
8A	VALVE SEAT (Part of #8 - Valve Assembly)	4	0205-0017
8B	VALVE POPPET (Part of #8 - Valve Assembly)	4	0205-0013
8C	VALVE SPRING (Part of #8 - Valve Assembly)	4	C1220-0001
8D	SPRING RETAINER (Part of #8 Valve Assembly)	4	0205-0014
9	O-RING FOR VALVE	4	C0100-1116
10	PLASTIC SPACER RING	8	0205-0016
11	GUIDE & VACUUM SEAL RETAINER	2	0311-0012
12	VACUUM SEAL	2	0311-0010
13	O-RING FOR VACUUM SEAL	2	C0100-1117
14	BEARING ASSEMBLY	1	0300-1000-0001
	ECCENTRIC INSERT (Part of #14 – Bearing Assembly)	1	0300-0001-0XXX
	BEARING 6205 (Part of #14 – Bearing Assembly)	1	C3000-0003
15	SOCKET HEAD CAP SCREW	2	C100-0504
16	WASHER AN TYPE	2	C1500-0004
KIT A	PLUNGER & SEALS – Includes 1, 2, 3, 4, 5, 12 & 13	1	PT042
KIT B	VALVES & O-RINGS – Includes 8, 9 & 10	1	PT044
KIT C	BEARING ASSEMBLY (#14)	1	PT046
	PUMP COMPLETE - WITHOUT MOTOR	1	PT058
	MOTOR	1	PT059
	MOUNTING BOLTS 3/8-16 X 2-3/4"	4	

CFS M1200 AUTO-FILL FLOAT VALVE ASSEMBLY

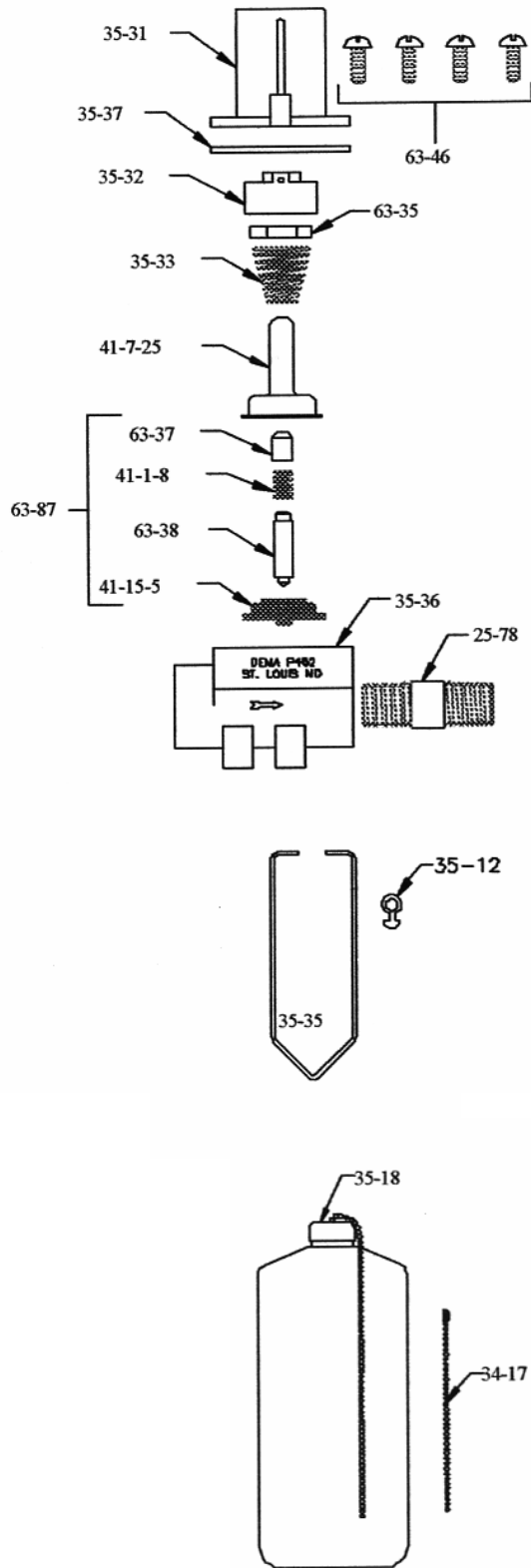

Part Number	Description
16-3	3' Discharge Tubing
25-78	Pipe Nipple
34-17	16" Chain with Connector
34-22	Backflow Preventer
35-12	Float Hanger Clip – PDE35-12
35-18	Float Assembly – PHY005-003
35-31	Magnet Housing
35-32	Magnet Holder
35-33	Spring
35-35	Float Hanger Wire – PDE35-42
35-36	Valve Body
35-37	Flange
41-1-8	Spring
41-7-25	Enclosing Tube
41-15-5	Diaphragm
61-121	Elbow 90° Street 1/4"
61-122	Adapter
61-107-2	Ceramic Weight
61-22-3	Proportioner – PDE61-22-3
63-35	Magnet
63-37	Spacer
63-38	Plunger
63-46	Screw 8-18 x 1/2" (4 req.)
63-87	Valve Repair Kit - PDE63-87 (Includes: 41-1-8, 41-15-5, 63-37 & 63-38)
100-3	Rubber Washer
100-11P	Foot Valve – Filter – PDE100-11P
100-12	8' x 1/4" Plastic Tubing – XAF1
100-15	Metering Tip - Turquoise

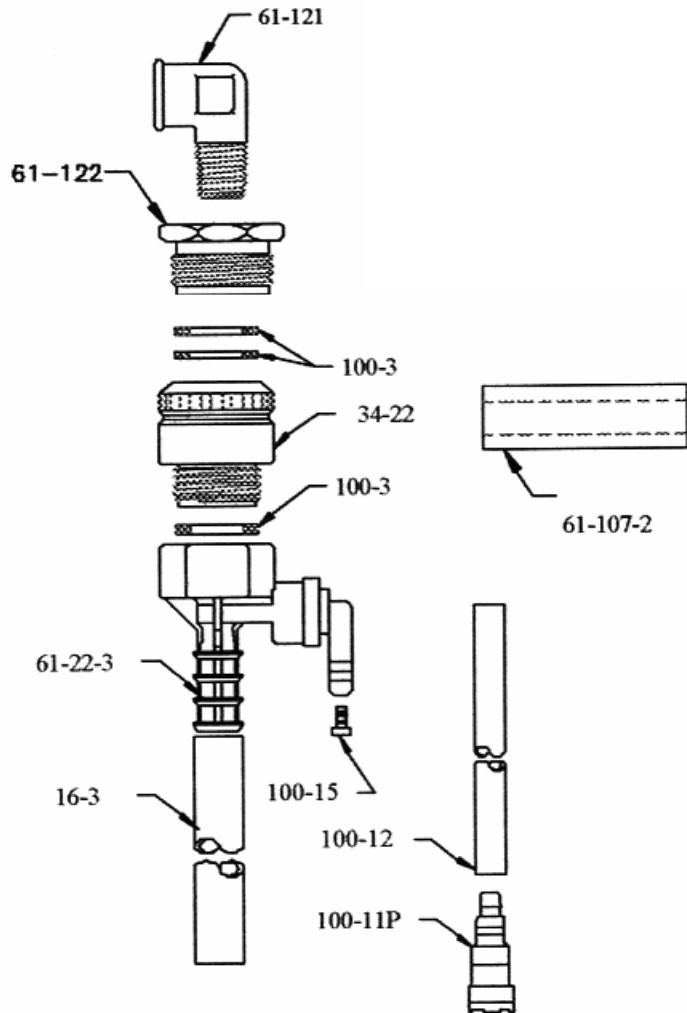

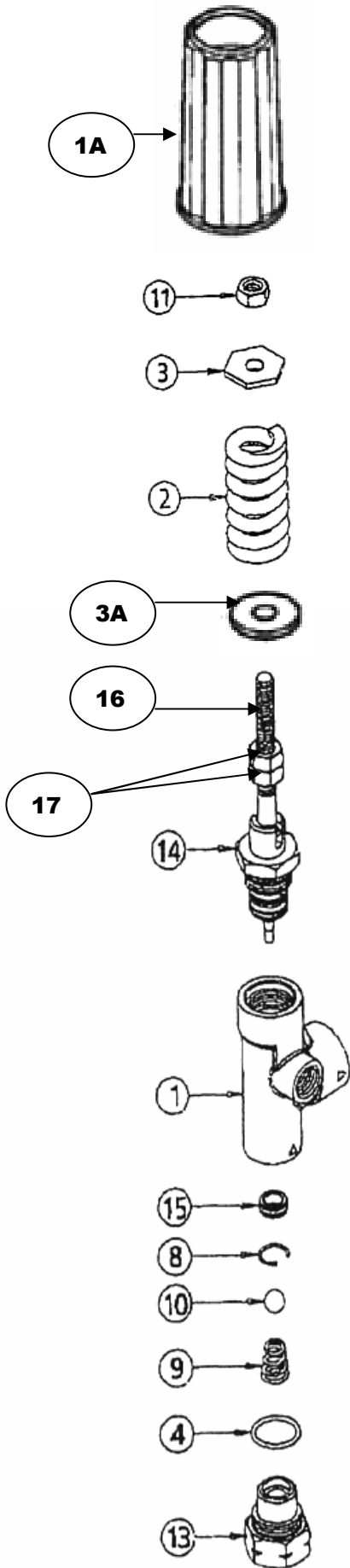

	DESCRIPTION
1	REGULATOR BODY
1A	REGULATOR KNOB
2	SPRING
3	SPRING PLATE
3A	SPRING WASHER
4	CAP / RETAINER O-RING (QTY 3)
5	POPPET O-RING
6	POPPET
7	POPPET SPRING
8	RETAINING RING
9	SPRING – BALL SEAT
10	BALL
11	STEM NUT
12	OUTLET ADAPTER CAP
13	INLET ADAPTER CAP
14	STEM RETAINER
15	SEAT
16	STEM
17	NUT – SET POINT LOCK (QTY 2)
18	STEM O-RING
19	STEM SPACER (QTY 2)
20	SMALL STEM O-RING
21	SMALL STEM SPACER (QTY 2)
22	ROLL PIN
NS	PT019A - REGULATOR REPAIR KIT (Includes: 4, 5, 6, 7, 8, 9, 10, 15, 18, 19, 20 & 21)

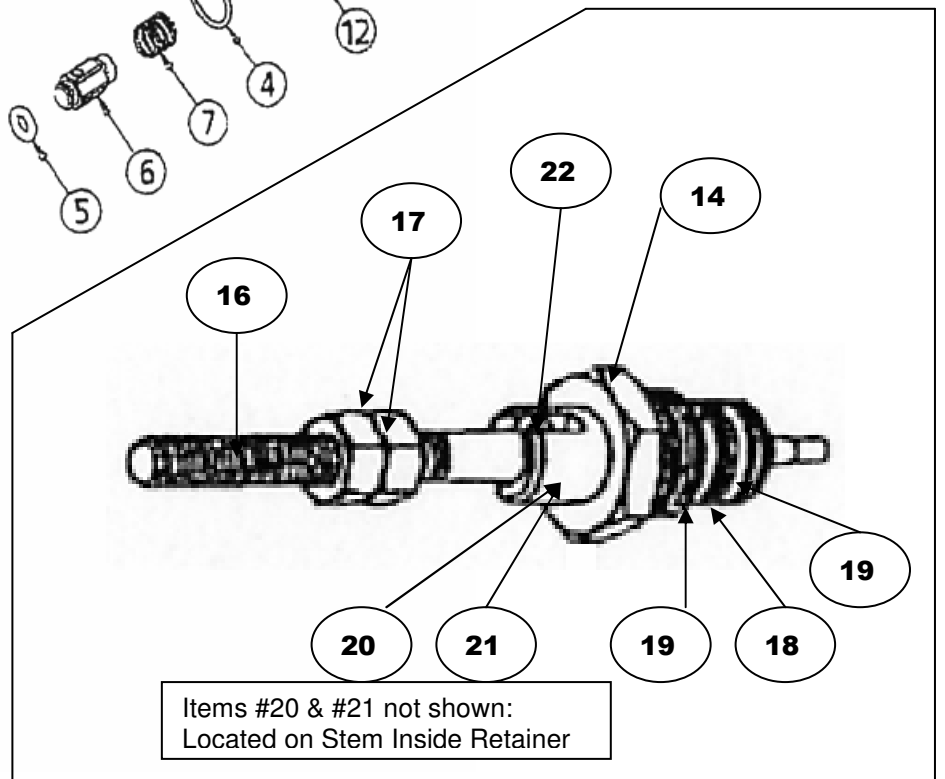

SOLUTION TANK

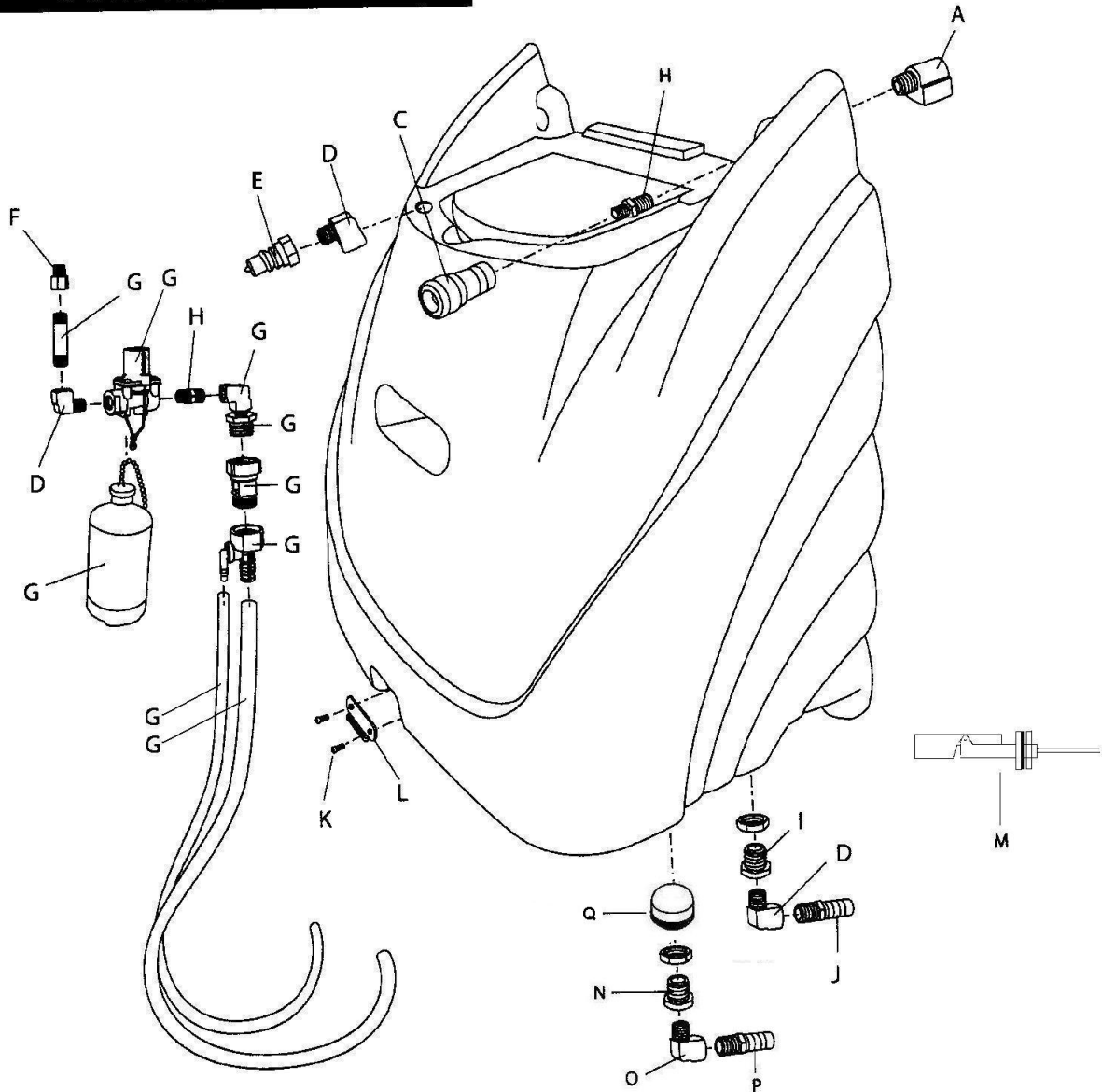

ITEM	PART #	DESCRIPTION	QTY	ITEM	PART #	DESCRIPTION	QTY
A	BR282	ELBOW 90 - 1/4" STREET	1	I	NM5087	BULKHEAD FITTING 1/4"	1
C	AH101B	QUICK CONNECT 1/4" FM	1	J	BR028	BARB 1/2" x 1/4" MPT	1
D	BR282	ELBOW 90 - 1/4" STREET	4	K	NM5023	SCREW 8-32 x 3/8" BH SOC SS	2
E	AH102B	QUICK CONNECT 1/4" M	1	L	NS121	LATCH HOOK	1
F	BR174	ADAPTER 1/4" MPT x 1/4" FPT BR	1	M	PHY157-031	FLOAT SWITCH - HP PUMP	1
G	NM5055	FLOAT VALVE ASSY W/CHEM	1	N	NM5098	BULKHEAD FITTING 3/8"	1
H	BR072	NIPPLE 1/4" HEX BRASS	2	O	BR284	ELBOW 90 - 3/8" STREET	1
				P	BR030	BARB 1/2" x 3/8" MPT	1
				Q	PP14-806504	STRAINER ACORN 3/4"	1

SOLUTION TANK INTERNAL

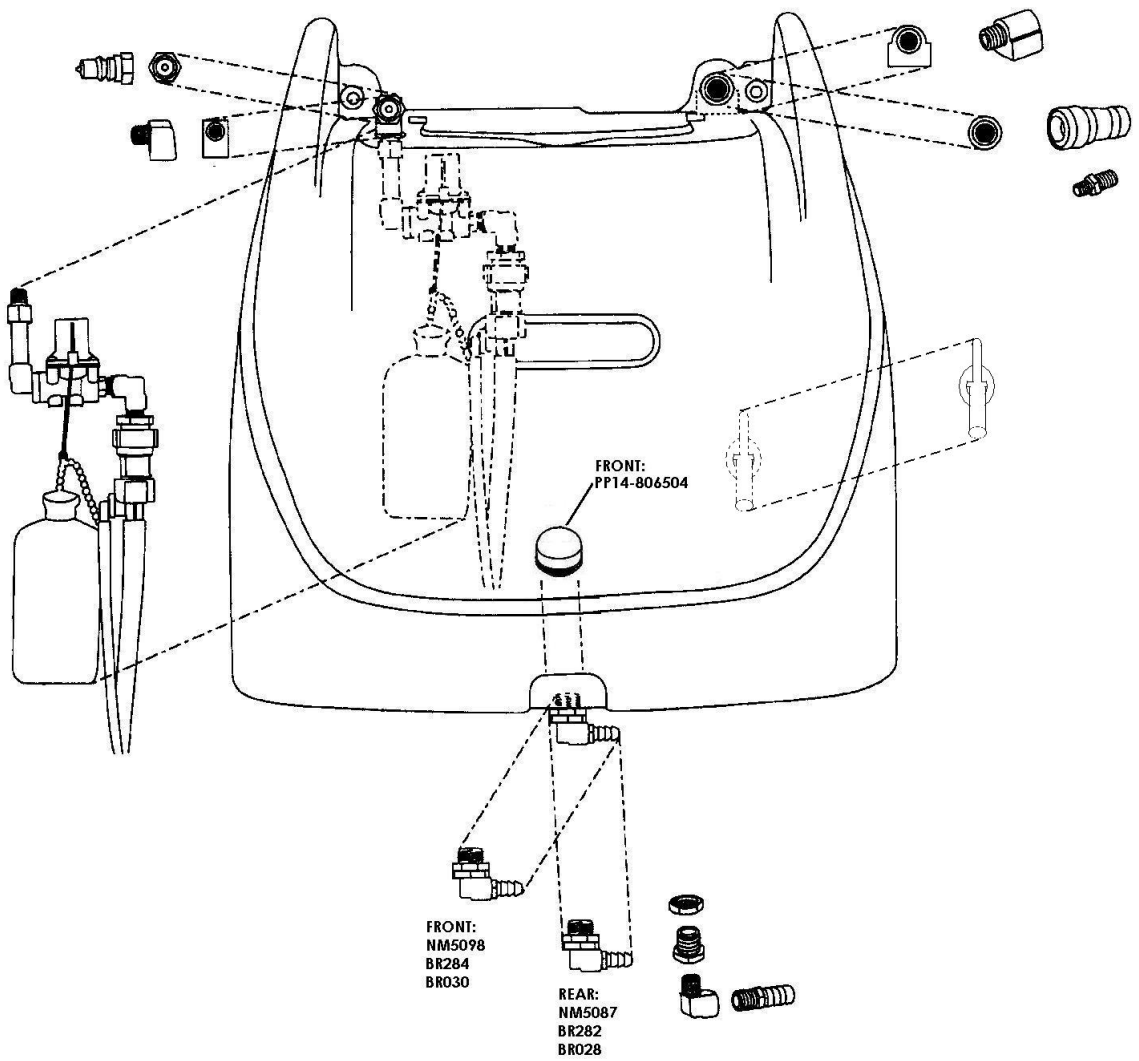

WASTE TANK

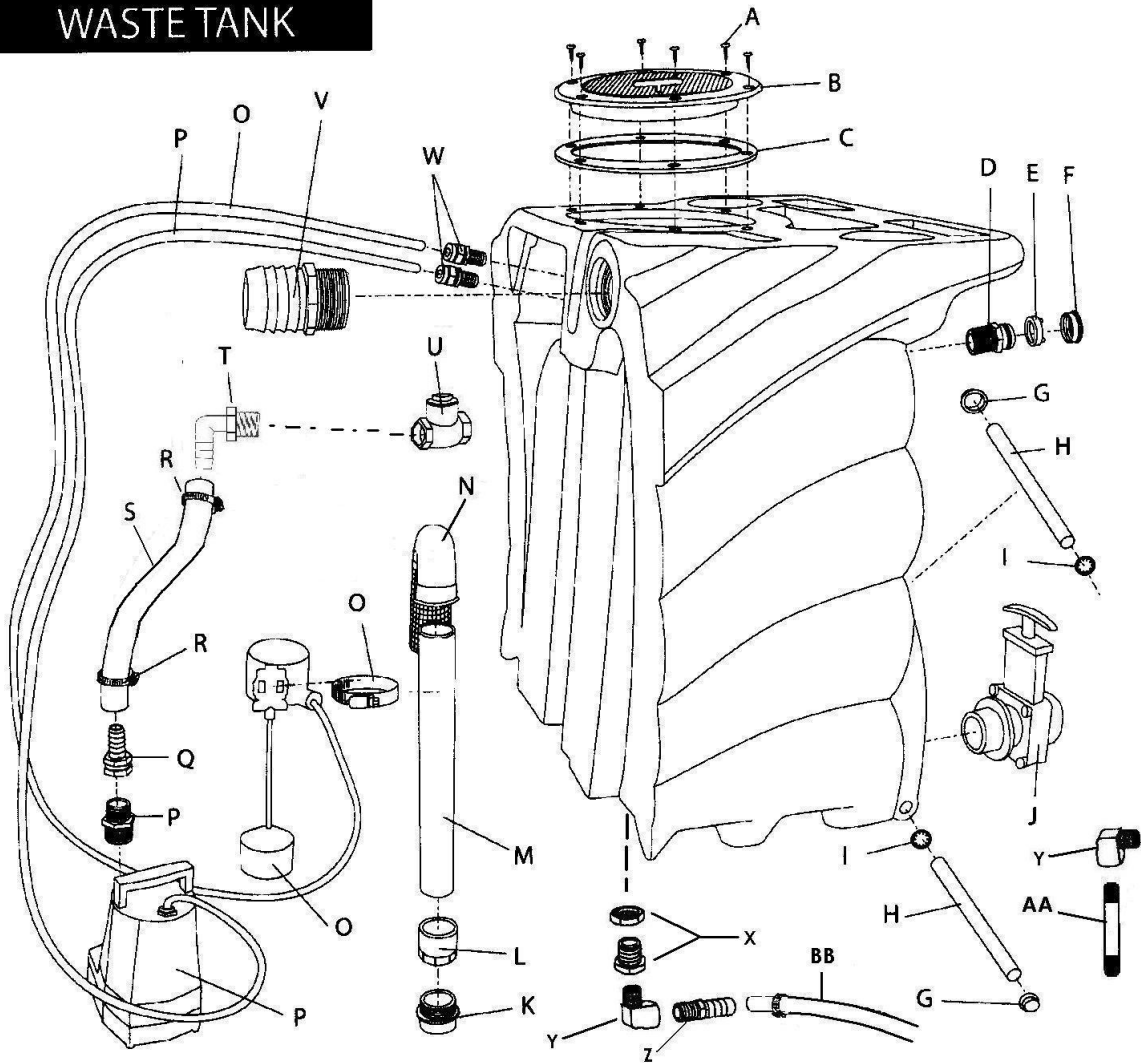

ITEM	PART #	DESCRIPTION	QTY	ITEM	PART #	DESCRIPTION	QTY
A	PA187	SCREW #10 x 5/8" SH	6	O	NM5054	SWITCH FLOAT STRAIGHT	1
B	NM5004	LID ASSEMBLY WASTER TANK	1	P	NM5053	PUMP LITTLE GIANT	1
C	NM5059	GASKET WASTE TANK LID	1	Q	BR333	BARB 3/4" x 3/4" FGH	1
D	BR319	ADAPTER 3/4" MPT X MGH	1	R	PH09	CLAMP HOSE SCREW 9/16"	2
E	BR600	GASKET	1	S	NM5056	HOSE 3/4" WATER BLACK	12"
F	BR325	CAP CARDEN HOSE BRASS	1	T	PA110	ELBOW 90 BARB 3/4" x 3/4" MP	1
G	NM5010	CAP AXLE OLYMPUS REAR	2	U	NM5052	CHECK VALVE 3/4" SWING	1
H	NM5013	HINGE POST	2	V	AH69	BARB 2" x 1-1/2" MPT	1
I	NM5026	HINGE RETAINING CLIP	2	W	NM5051	STRAIN RELIEF	2
J	PEA11	VALVE 1-1/2" MPT GATE	1	X	NM5087	BULKHEAD FITTING 1/4"	1
K	NM5042	ADAPTER 1-1/2" MPT X 1-1/2" MS	1	Y	BR282	ELBOW 90 - 1/4" STREET	2
L	NM5081	ADAPTER 1-1/2" FPT X 1-1/2" FS	1	Z	BR020	BARB 3/8" x 1/4" MPT	1
M	NM5036	PIPE 1-1/2" X 17" A B S	16"	AA	BR083	NIPPLE 1/4" x 3"	1
N	NM5037	FLOAT & FILTER CAGE	1	BB	NM5082	HOSE 3/8" CLEAR COIL	28"

WASTE TANK SIDE INTERNAL VIEW

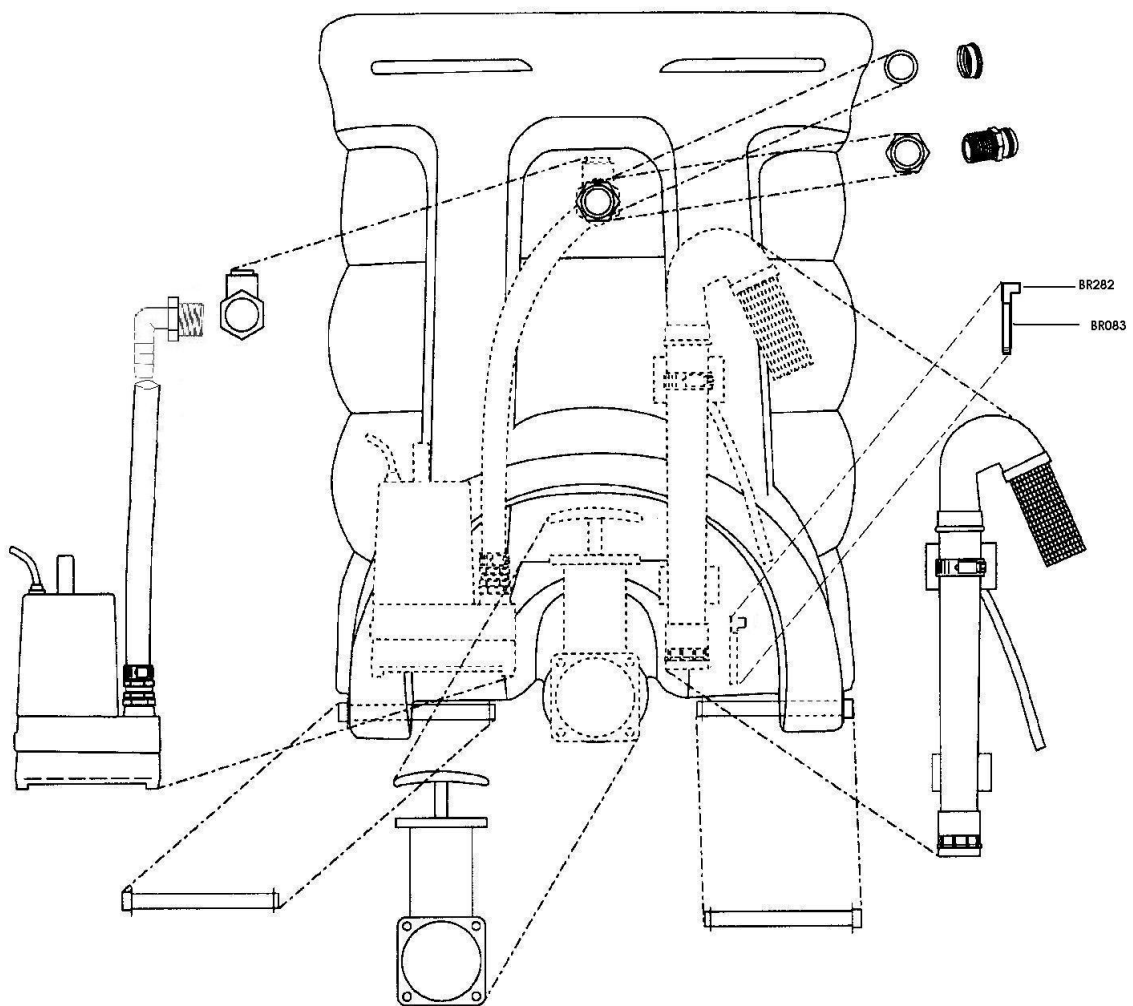

BASE WITH VACUUMS & COMPONENTS

M1200

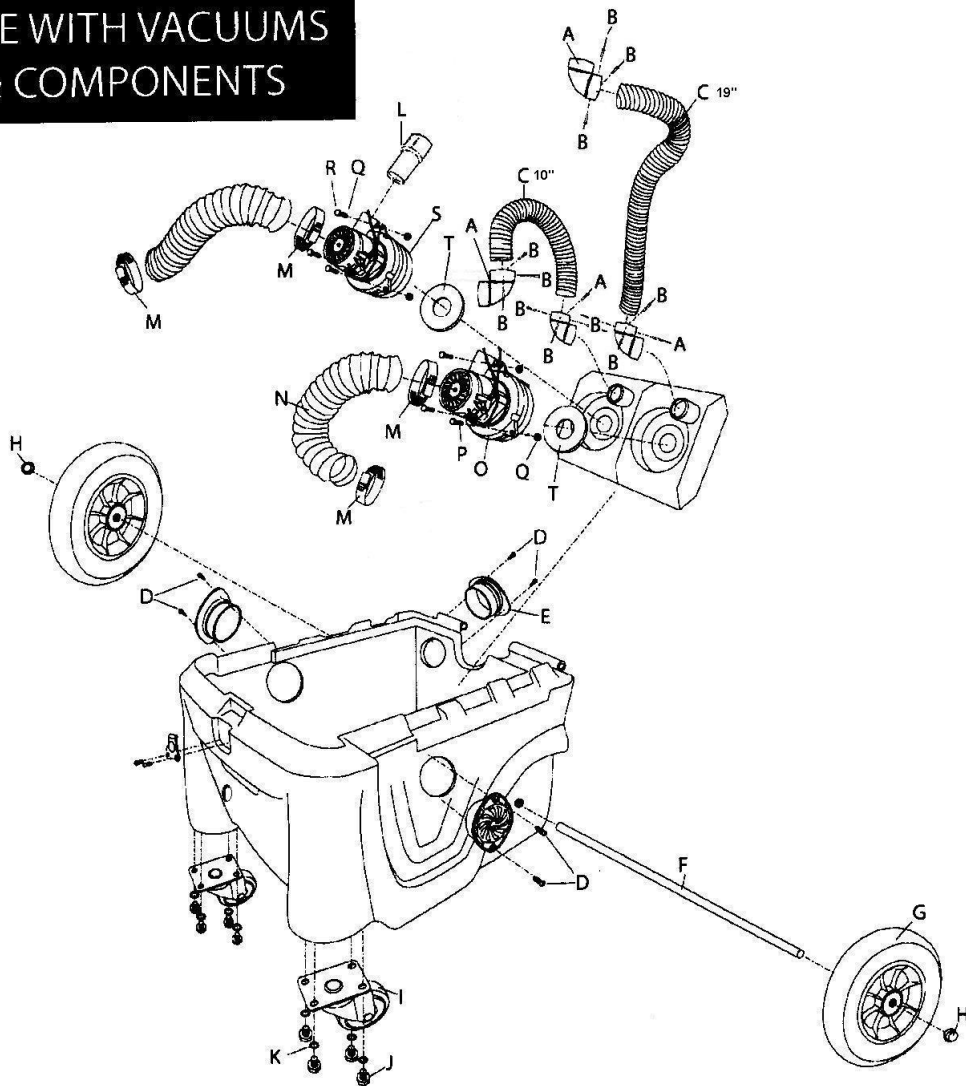

ITEM	PART #	DESCRIPTION	QTY	ITEM	PART #	DESCRIPTION	QTY
A	NM5041	ELBOW 90 - 1-1/2" ABS	4	K	NM5014	WASHER LOCK - CASTER	8
B	NM5025	RIVET HOSE ELBOW	12	L	AH42	CUFF 1-1/2" HOSE	1
C	NM5050	VAC HOSE 1-1/2" WIRE REINFORCE	29"	M	PHO14	CLAMP HOSE SCREW 3"	4
D	PA184	SCREW 8x3/8 SHEET METAL	12	N	NM5018	DUCT 3" x 18" VINYL BLACK	2
E	NM5015	GRATE VAC EXHAUST	3	O	AV010	VAC MOTOR 5.7 2 STAGE	1
F	NM5011	AXLE OLYMPUS REAR WHEEL	1	P	NM5029	SCREW 10-32 x 5/8" SS	3
G	NM5002	REAR OLYMPUS WHEEL	2	Q	NM5033	WASHER MANIFOLD BOTLS	6
H	NM5010	REAR WHEEL AXLE CAP	2	R	NM5089	SCREW 10-32x101/2" SS	3
I	NM5003	FRONT CASTER	2	S	AV14	VAC MOTOR 5.7" 3 STAGE	1
J	NM5012	SCREW 1/4-20 x 1" HX HD	8	T	PA010	GASKET VAC MOTOR 5.7"	2

BASE WITH PUMP & COMPONENTS

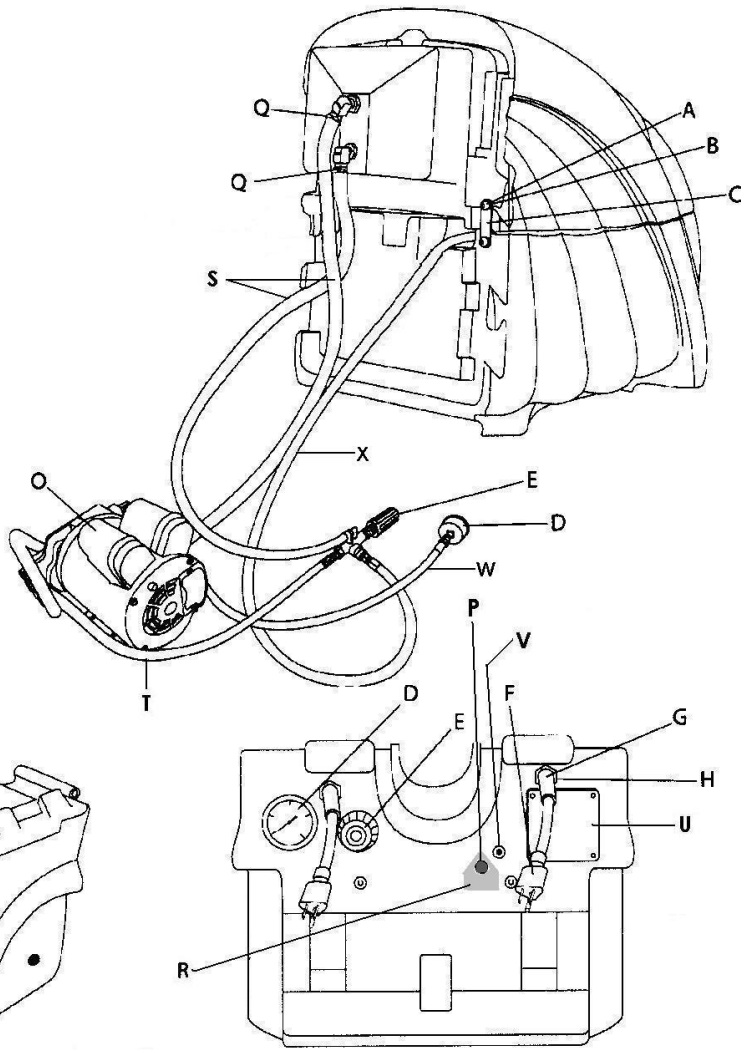
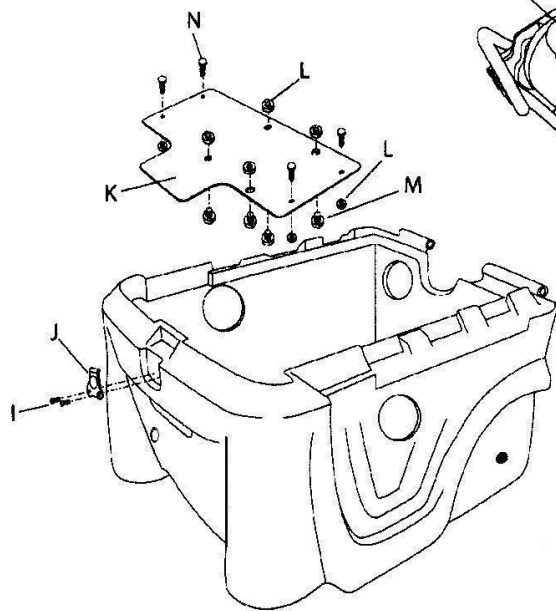

REAR VIEW

ITEM	PART #	DESCRIPTION	QTY
A	NM5028	SCREW 1/4-20x1/2" SS SOC HD	4
B	NM5030	WASHER 1/4" FLAT BLACK	4
C	NM5027	BRACKET SOL/REC TANK	2
D	PT063	PRESSURE GUAGE 2000 PSI	1
E	PT019	PRESSURE REGULATOR 1200 PSI	1
F	NM5009	CORD 12/3x2' W/MALE END	2
G	NM5038	STRAIN RELIEF	2
H	NM5039	NUT STRAIN RELIEF	2
I	NM5023	SCREW 8-32x3/8" BH SOC SS	2
J	NS121	LATCH HOOK	1
K	NM5064	PLASTIC INSERT M1200	1
L	NM4003	NUT 1/4-20 HEX SS	8
M	NM5012	SCREW 1/4-20x1/2" HX HD	4

ITEM	PART #	DESCRIPTION	QTY
N	NM5034	SCREW 1/4-20x1" HX HD	4
O	AP48	PUMP PUMPTEC #356 1200 PSI	1
P	NX201	BREAKER BUDDY LIGHT -GREEN	1
Q	PH09	CLAMP HOSE SCREW 9/16-1 1/4"	6
R	NX202	DECAL BREAKER BUDDY	1
S	NM5086	HOSE 1/2" CLEAR COIL	9' OR 108"
T	PT070	PULSE HOSE M1200	1
U	NM5015	GRATE VAC EXHAUST	3
V	PHY018-005	PUMP CIRCUIT BREAKER 20AMP	1
W	PH501	HP HOSE 26" 3/8" IMS X 1/4" F	1
X	PH509	HP HOSE 45" 1/4" IMS X 3/8" MS	1
NOT SHOWN	NM5096	PUMP PRIMING VALVE	1
NOT SHOWN	NM4451	RELAY	1
NOT SHOWN	NM5447	RELAY BOX	1
NOT SHOWN	NM5448	RELAY BOX COVER	1

Limited Warranty

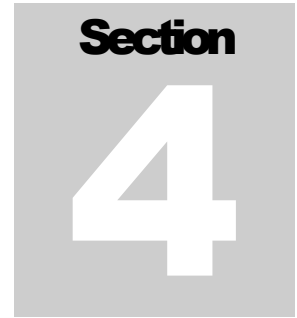

Your CFS M1200 is designed to give you years of reliable service. If a problem should arise use the troubleshooting section in the operation manual to diagnose and correct the problem if possible.

If you are unable to determine the cause or solution to the problem contact HMS Manufacturing for assistance.

HMS Manufacturing warrants the roto-molded tanks and base of the CFS M1200 to be free from defects in material or workmanship for five years from the date of purchase.

All other components of the CFS M1200 are warranted to be free of defects in material and workmanship for one year from the date of purchase.

During the warranty period, HMS Manufacturing will, at its option repair or replace components which prove to be defective. This warranty does not provide for replacement of complete units due to defective components. Any costs for transportation or related service labor are not covered in this warranty. Replacement parts are warranted only for the remainder of the original warranty period.

This warranty shall not apply to defects resulting from improper operation, lack of maintenance, unauthorized modification, chemical incompatibility, misuse, abuse or exposure to freezing temperature conditions. It does not cover normal wear items such as o-rings, valve seals, pump seals, hoses, jets, cords, batteries, or other items which require replacement as a result of ordinary usage.

To obtain warranty service for the CFS M1200, contact HMS Manufacturing. If the extractor must be returned to HMS Manufacturing, the purchaser shall prepay shipping charges for products returned for warranty service. No returned items will be accepted by HMS Manufacturing without prior authorization. All returns must have a return authorization number, issued by HMS Manufacturing, clearly marked on the exterior of the package.

HMS Manufacturing makes no other warranty either expressed or implied with respect to this product.

The remedies provided herein are the purchaser's sole and exclusive remedies. In no event shall HMS Manufacturing be liable for any direct, indirect, special, incidental or consequential damages.

This warranty gives you specific legal rights. You may also have other rights which vary from jurisdiction to jurisdiction.